

## LCD Fundamentals and the LCD Driver Module of 8-Bit PIC<sup>®</sup> Microcontrollers

*Authors: Mary Tamar Tan  
Rodger Richey  
Microchip Technology Inc.*

### INTRODUCTION

The popularity of Liquid Crystal Displays (LCD) has rapidly soared over the years due to the numerous advantages it offers over other display technologies. This application note provides an introduction to the basics of LCD; its construction, physics behind its operation, and the different factors affecting its properties and performance. Moreover, 8-bit PIC<sup>®</sup> microcontrollers with integrated LCD controllers are also introduced. Prominent features of the LCD Driver module of these MCU families are discussed, including contrast control, drive waveforms, biasing methods, power modes, and other LCD circuit design considerations. Lastly, the code samples for a 1-Hour Countdown Timer application for both the PIC16 and PIC18 devices are presented. The application uses the segmented and dot matrix LCD for the two families, respectively.

### LIQUID CRYSTALS

Liquid Crystals (LCs) exist in a state between isotropic (liquid) and crystalline (solid), and exhibit the properties of both as shown in [Figure 1](#). Nematic phase, which is the simplest of the LC phases, is the one employed in the LCD technology.

LCs are affected by electric current and when a voltage is applied, they react and may change order and arrangement. This unique behavior of LCs allows them to play a significant role in electro-optic devices, such as the LCD.

**FIGURE 1: LIQUID CRYSTAL PHASES**

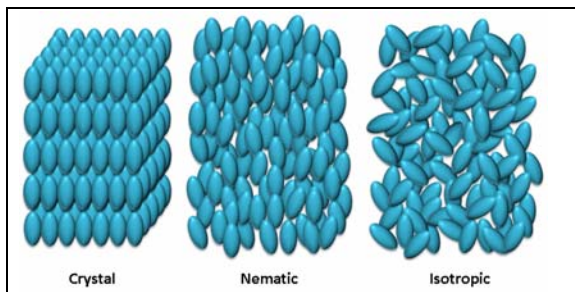

### BASIC COMPONENTS OF AN LCD PANEL

An LCD panel, or more commonly known as a piece of “glass”, is constructed of many layers. [Figure 2](#) shows all the layers that are typically present in LCD panels. For this application, it is assumed that the LCD employs a Twisted Nematic (TN) display, unless otherwise stated. TN displays, as well as the other display technologies are discussed in detail in the [Section “LCD Technologies”](#).

**FIGURE 2: BASIC LCD COMPONENTS**

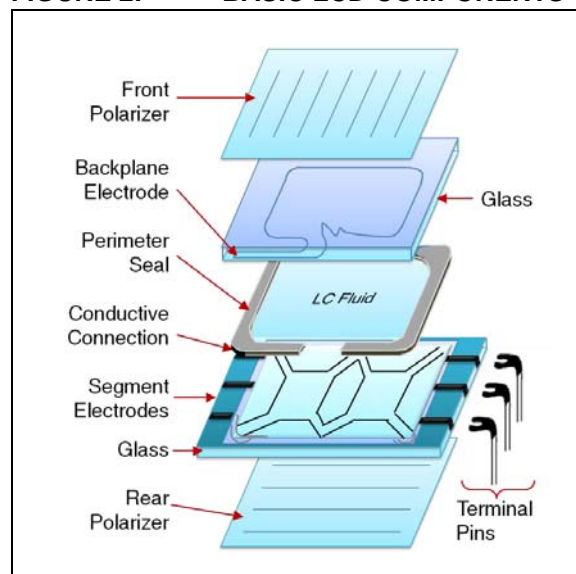

Polarization is the process or state in which rays of light exhibit different properties in different directions, especially the state in which all the vibration takes place in one plane. Essentially, a polarizer passes light only in one plane. As shown in Figure 3, if light is polarized in one plane, by passing through a polarizer, it cannot pass through a second polarizer if its plane is 90° out of phase to the first.

The front polarizer is applied to the outside surface of the top piece of glass. The top piece of glass also provides structural support for the LCD panel.

**FIGURE 3: OUT OF PHASE AND IN-PHASE POLARIZERS**

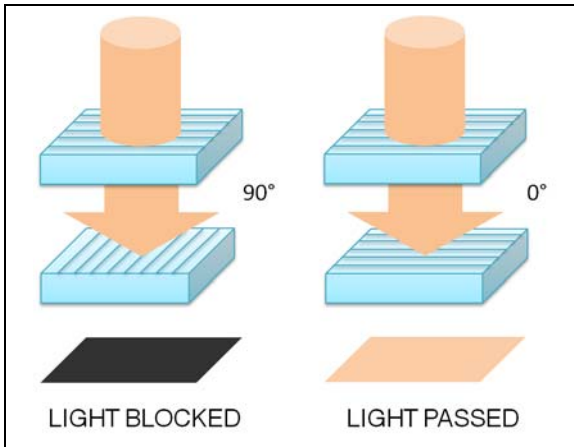

On the bottom of the top glass, a transparent coating of Indium Tin Oxide (ITO) is applied to the glass. ITO is conductive and forms the backplane or the common electrodes of the LCD panel. The patterns of the backplane and segment ITO form the numbers, letters, symbols, icons, etc.

After the ITO has been applied to the glass, a thin polyimide coating is applied to the ITO. The polyimide is “rubbed” in a single direction that matches the polarization plane of the front polarizer. The action of “rubbing” the polyimide causes the Liquid Crystal (LC) molecules in the outermost plane to align themselves in the same direction.

The next layer is a reservoir of LC. The LC fluid has many planes of molecules.

The next layer is the polyimide coating on the bottom glass followed by the ITO segment electrodes. The bottom glass also supplies structural integrity for the LCD panel as well as mounting surface for the electrode connections. Applied to the external surface of the bottom glass is the rear polarizer. Depending on the type of viewing mode employed by the LCD panel, the axis of polarization is the same or 90° apart from the front polarizer.

LC molecules are long and cylindrical. On any plane within the LC fluid, the molecules align themselves such that the major axis of each molecule is parallel to all others, as shown in Figure 4. The outermost planes of the LC molecules will align themselves on the same axis that the polyimide is “rubbed”. The direction of “rubbing” of the polyimide on the bottom glass is 90° apart from that of the polyimide on the top glass. This orientation creates the twist in the LC fluid.

**FIGURE 4: LC MOLECULES IN ALIGNMENT**

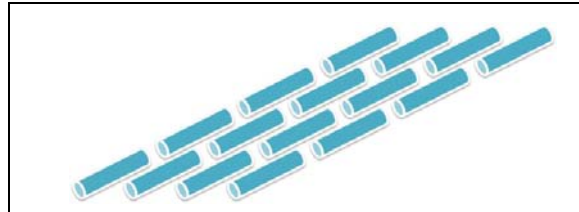

A consequence of this alignment is that each intermediate plane of LC molecules will have a slightly different orientation from the plane above or below as seen in Figure 5.

The twisting of the planes causes the polarization of the light to twist as it passes through the LC fluid. The twisting of the LC planes is critical to the operation of the LCD panel as will be shown in the next section.

**FIGURE 5: LC MOLECULES PLANE ORIENTATION**

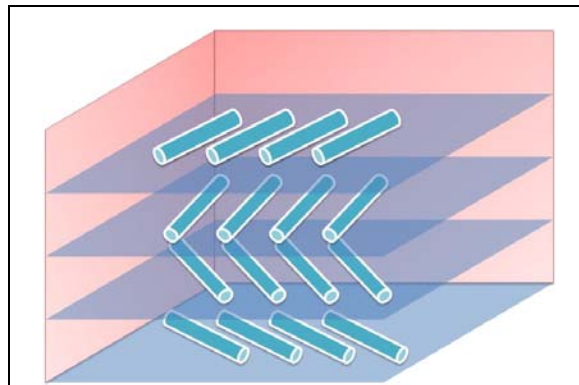

## HOW AN LCD WORKS

As explained in the previous section, the twist created in the LC fluid is the basis of how the panel operates. An LCD basically produces an output display by the switching of segments or pixels between ON or OFF. A pixel is considered to be ON when enough electric potential is applied between the segment and common electrodes, resulting to a dark pixel on the display. On the contrary, a pixel is considered to be in the OFF state when insufficient electric potential is applied between the electrodes, creating a clear pixel on the display.

### OFF Pixel

Figure 6 shows how an LCD panel creates a pixel that is OFF. For this example, the LC fluid is not energized (i.e., there is 0 VRMS potential between the common and the segment electrodes). The following is a step-by-step description of the path light takes through the LCD panel. The illustrative representation of the process is shown in Figure 8.

**FIGURE 6: LC ORIENTATION WITH NO ELECTRIC FIELD**

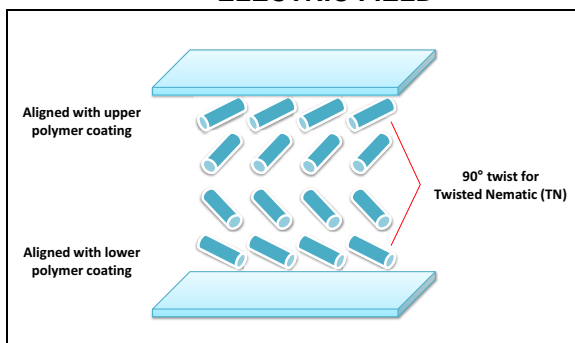

- Light enters the panel through the rear polarizer. At this point, light becomes polarized to the vertical plane.
- The polarized light passes unobstructed through the transparent common electrode.
- As the polarized light passes through the LC fluid, it gets twisted into the horizontal plane.
- The polarized light passes unobstructed through the transparent segment electrode.
- Since the light is now polarized in the horizontal plane, it passes unobstructed through the front polarizer which has a horizontal polarization.
- The observer does not detect that the pixel is ON because the light has not been obstructed.

### ON Pixel

If a potential is applied across the common and segment electrodes, the LC fluid becomes energized. The LC molecule planes will now align themselves such that they are parallel to the electrical field generated by the potential difference. This removes the twisting effect of the LC fluid. Figure 7 shows how a pixel that is ON, or more specifically energized, is created. The following is a step-by-step description of the path that the light takes through this LCD panel. Refer to Figure 9 for the illustrative representation.

**FIGURE 7: LC ORIENTATION WITH ELECTRIC FIELD**

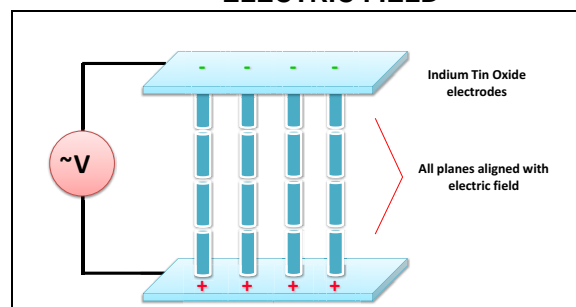

- Light enters the panel through the rear polarizer. At this point, the light becomes polarized to the vertical plane.
- The polarized light passes unobstructed through the transparent common electrode.
- As the polarized light passes through the LC fluid, it does not twist and remains in the vertical plane.
- The polarized light passes unobstructed through the transparent segment electrode.
- Since the light is still polarized in the vertical plane, it is obstructed by the front polarizer which has a horizontal polarization.
- The observer detects that the pixel is ON because the light has been obstructed and creates a dark image on the panel.

**FIGURE 8: PATH OF LIGHT FOR OFF PIXEL (POSITIVE IMAGE)**

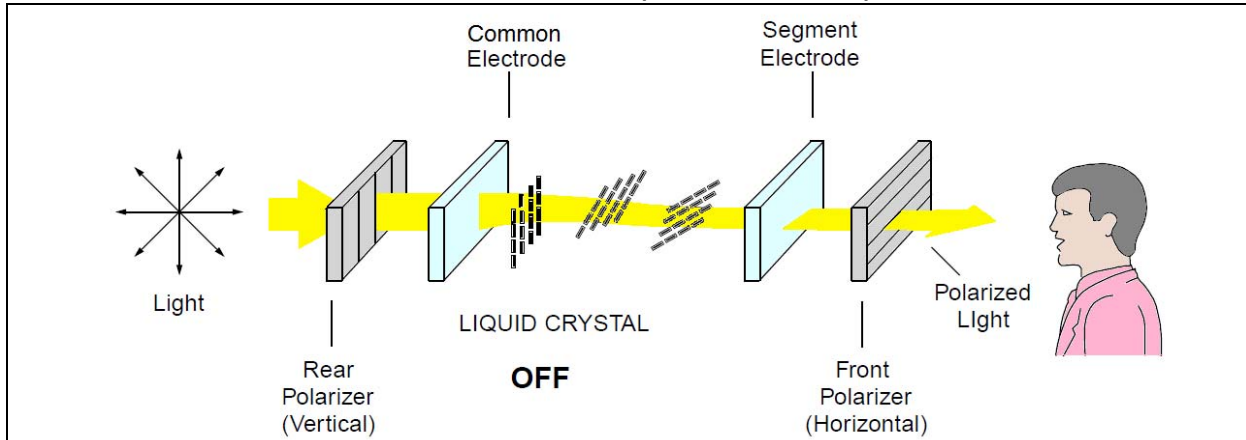

**FIGURE 9: PATH OF LIGHT FOR ON PIXEL**

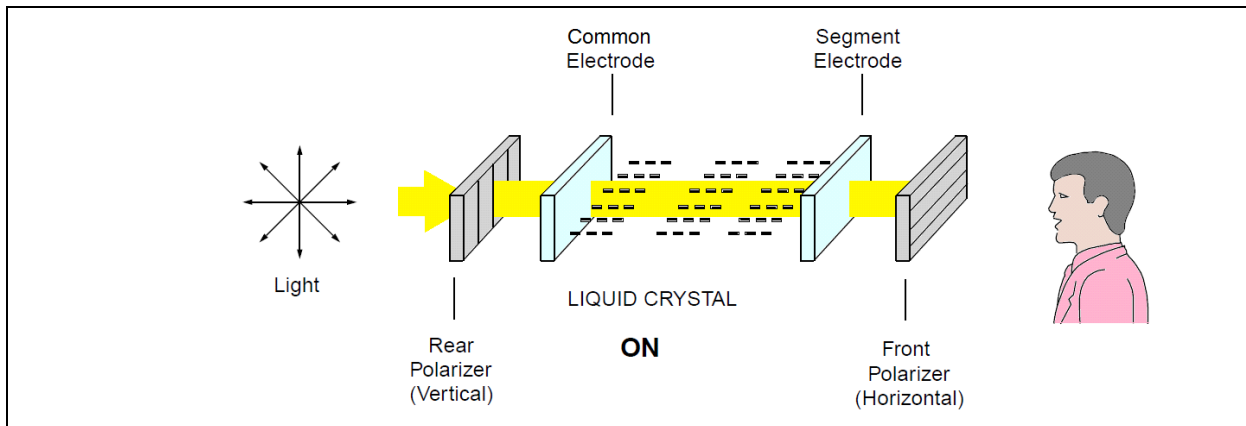

**LCD IMAGES**

LCDs have the capability to produce both positive and negative images. The selection of the type of image is based on the requirements of the application.

**FIGURE 10: POSITIVE AND NEGATIVE IMAGE**

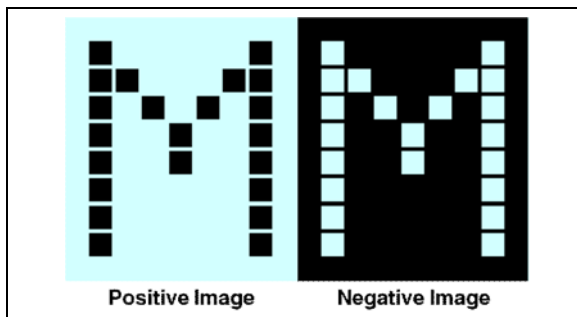

**Positive Image**

A positive image is defined to be a dark image on a light background, as shown in Figure 10. In a positive image display, the front and rear polarizers are perpendicular to each other. Unenergized pixels and the background transmit the light and energized pixels obstruct the light creating dark images on the light background. Positive images are usually used in applications where ambient light is high and it is also capable of multiple background colors.

**Negative Image**

Unlike a positive image, a negative image is a light image on a dark background (see Figure 10). In this type of display, the front and rear polarizers are aligned to each other. Unenergized pixels and the background inhibit light from passing through the display. Energized pixels allow the light to pass creating a light image on a dark background. Typically, negative images are employed in backlit LCDs with medium to dim ambient lighting conditions. The display is also capable of multiple pixel colors.

## LCD Viewing Modes

There are essentially three types of viewing modes for an LCD: reflective, transmissive, and transreflective.

### Reflective Displays

Typically, reflective displays use only positive images. The front and rear polarizers are perpendicular to each other. The LCD panel will have an additional layer added to the bottom of the display, a reflector. Figure 11 shows the diagrams for pixels that are ON and OFF for reflective displays. The path that light takes is described below in a step-by-step fashion for a pixel that is OFF in a positive image display.

- Light enters the panel through the front polarizer. At this point, the light becomes polarized to the vertical plane.
- The polarized light passes unobstructed through the transparent common electrode.

- As the polarized light passes through the LC fluid, it gets twisted into the horizontal plane.
- The polarized light passes unobstructed through the transparent segment electrode.
- Since the light is now polarized in the horizontal plane, it passes unobstructed through the rear polarizer which has a horizontal polarization.
- The reflector behind the rear polarizer reflects the incoming light back on the same path.
- The observer does not detect that the pixel is ON because the light was reflected back.

A pixel that is ON follows the same basic steps except that the light never reaches the reflector and therefore does not return to the observer. Reflective displays lend themselves to battery-powered applications because the images are created using ambient light sources. These displays are very bright under proper lighting conditions, exhibit excellent contrast, and have a wide viewing angle.

**FIGURE 11: REFLECTIVE LCD PATH OF LIGHT**

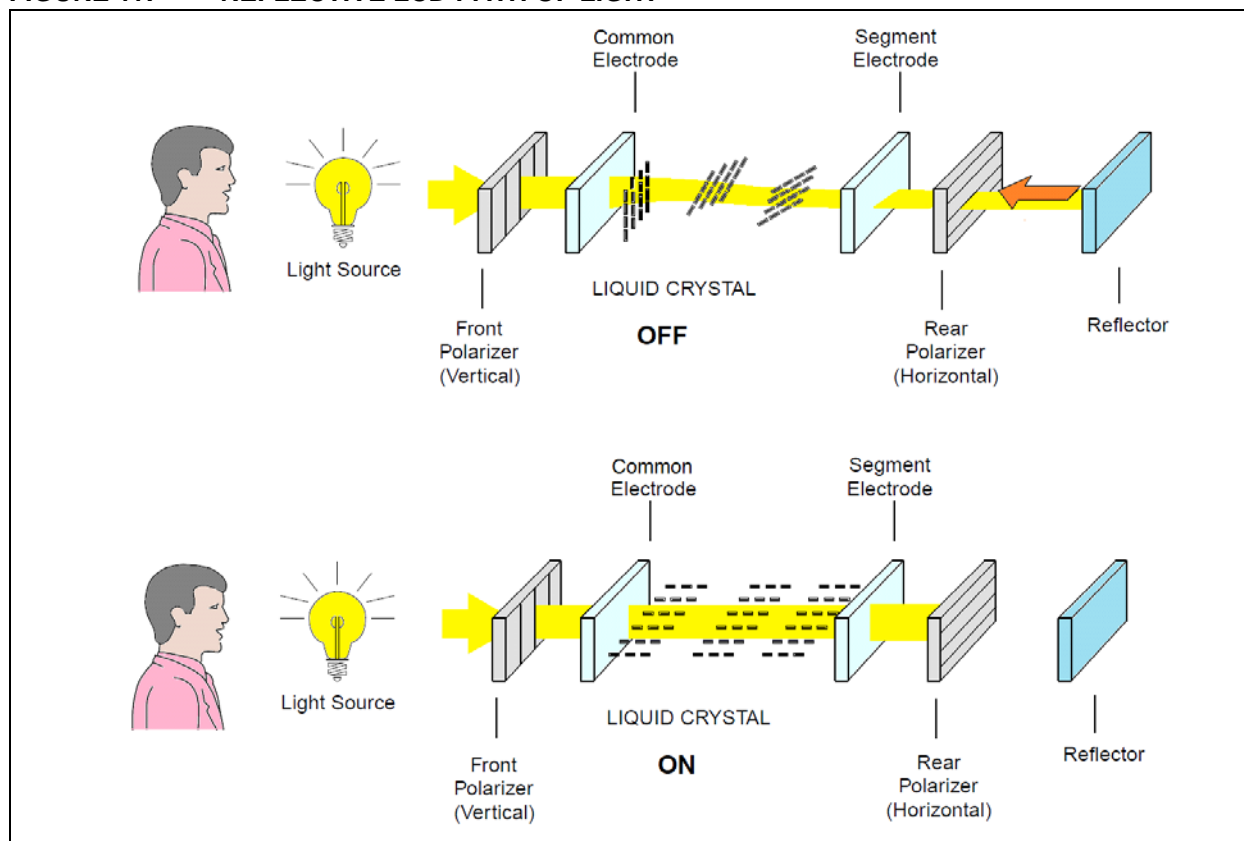

## Transmissive Displays

Transmissive displays do not reflect light back to the observer. Instead, they rely upon a light source behind the panel to create images. A transmissive display has front and rear polarizers that are in phase to each other. Figure 12 shows the ON and OFF diagrams for a transmissive display. The path of light is described below for the ON state only in a negative image display.

- Light enters the panel through the rear polarizer. At this point, the light becomes polarized to the vertical plane.
- The polarized light passes unobstructed through the transparent segment electrode.
- As the polarized light passes through the LC fluid it gets twisted into the horizontal plane.

- The polarized light passes unobstructed through the transparent common electrode.
- Since the light is now polarized in the horizontal plane, it is obstructed by the front polarizer which has a vertical polarization. Very little light passes through the front polarizer.
- The observer detects that the pixel is ON because the light was obstructed.

An OFF pixel would allow the light to pass through the display unobstructed because the polarization does not get twisted by the LC fluid. These displays are very good for very low light level conditions. They are very poor when used in direct sunlight because the sunlight swamps out the backlighting.

**FIGURE 12: TRANSMISSIVE LCD PATH OF LIGHT**

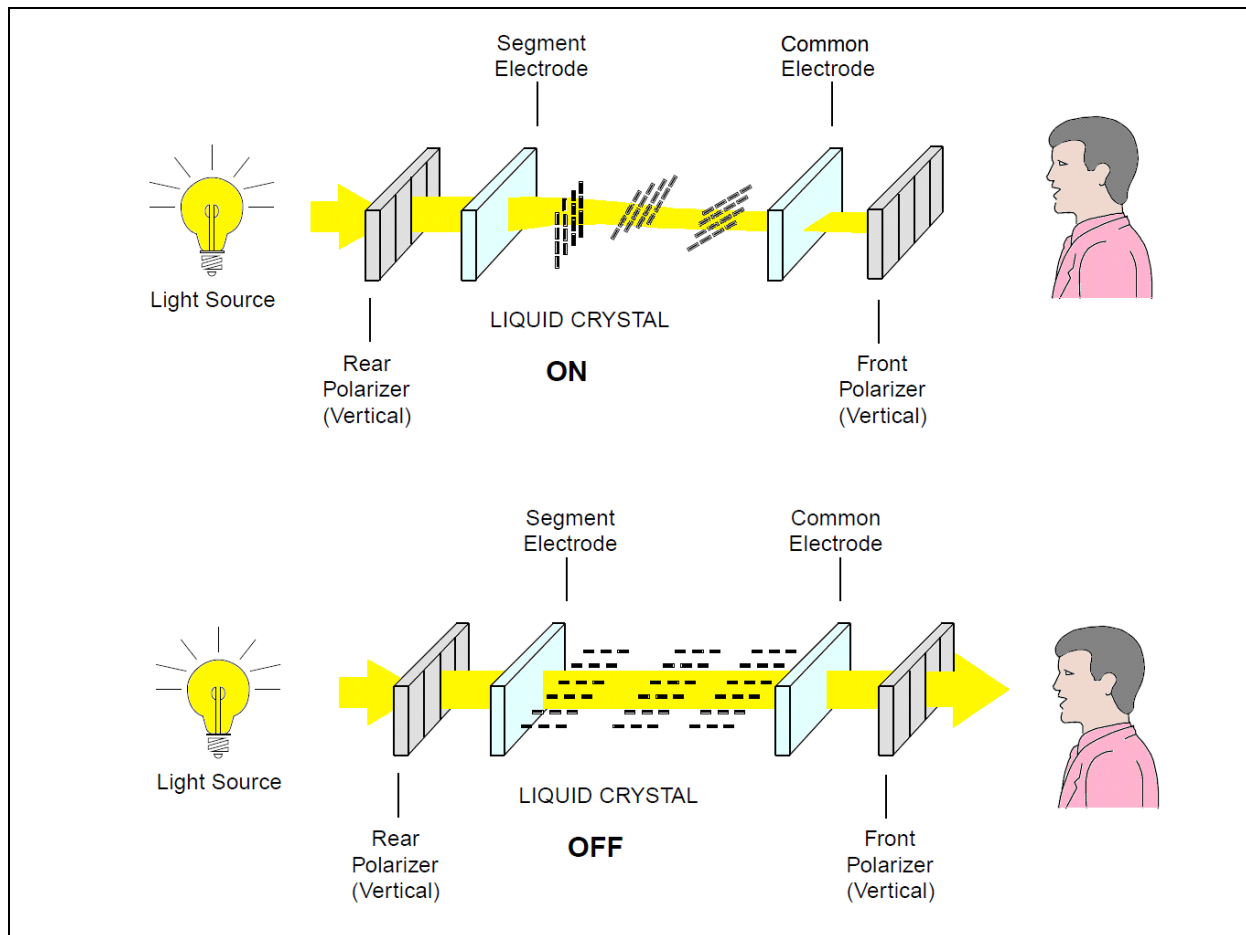

## Transflective Displays

The third type of display is called transflective. As what the name implies, it is a combination of reflective and transmissive. It reflects some of the ambient light back to the observer while also allowing backlighting. Transflective displays are very good for applications such as gas pumps.

The type of LCD that an application requires is largely dependent on the ambient light available. [Table 1](#) gives some guidelines for selecting a display according to the lighting conditions.

**TABLE 1: LIGHTING CONDITION REFERENCE**

Viewing Mode	Display Description	Application Comments	Direct Sunlight	Office Light	Very Low Light
Reflective (Positive)	Dark images on light background	No backlighting. Gives best contrast and environmental stability.	Excellent	Very good	Unusable
Transflective (Positive)	Dark images on gray background	Can be viewed with both ambient light and backlighting	Excellent (no backlight)	Good (no backlight)	Very Good (backlight)
Transflective (Negative)	Light gray images on dark background	Requires high ambient light or backlighting	Good (no backlight)	Fair (no backlight)	Very Good (backlight)
Transmissive (Negative)	Backlight images on dark background	Cannot be viewed by reflection	Poor (backlight)	Good (backlight)	Excellent (backlight)
Transmissive (Positive)	Dark images on a backlight background	Good for very low-light conditions	Poor (backlight)	Good (backlight)	Excellent (backlight)

## LCD BACKLIGHTING

An LCD is considered a passive device since it does not emit light by itself to produce the output display, but simply alters the light passing through it. For this reason, it needs illumination or light from external sources to produce a visible image. LCDs use a source of light coming from the rear of the display, or what is commonly known as the backlight.

In choosing the best backlighting for a specific application, it is necessary to consider several factors, such as cost, features and appearance. Backlighting has a significant effect on the contrast, brightness, and other display properties of an LCD. Each method has its own advantages and disadvantages. This section provides a brief discussion on the different backlighting methods and some of their common applications. [Table 2](#) shows a comparison between the features of these backlighting methods.

**TABLE 2: BACKLIGHTING FEATURES COMPARISON**

Feature	LED	Incandescent	Electroluminescent	CCFL	Fiber Optic
Brightness	Medium-High	High	Low-Medium	High	Medium-High
Color	Many	White	White	White	Many
Size	Small	Small-Medium	Thin	Small-Medium	Thin
Voltage	3.6 Vdc-12 Vdc	1.5 Vdc-28 Vdc	2 Vdc-7 Vdc (requires inverter)	5 Vdc-28 Vdc (requires inverter)	2.2 Vdc-3.6 Vdc
Current @5V/sq. in	1 mA-30 mA	20 mA	1 mA-10 mA	5 mA-10 mA	10-30 mA
Temperature	Warm	Hot	Cool	Warm	Cool
Shock Tolerance	Excellent	Fragile	Excellent	Good	Excellent
Life (hours)	100,000	150-10,000	500-15,000	10,000-60,000	100,000

### LED Backlight

A Light Emitting Diode (LED) is a semiconductor device that emits light when electric current passes through it. It is an excellent light source in terms of operational voltage, cost, intensity control, and some LEDs can even have a life span of almost 100,000 hours. LED has become the most popular backlighting for small and medium LCDs. LED backlighting also comes in a variety of colors. It has two basic configurations: Edge-lit and Array-lit.

As the name implies, the light source comes from the edge(s) in an edge-lit configuration. The light is then diffused into the screen through a light guide or light pipe. Edge-lit LCDs are often extremely thin, cheap, and power efficient. One drawback of edge-lit LCDs is that light distribution is not always equal which affects the image quality.

In an array-lit configuration, several rows of LEDs are mounted uniformly behind the entire display area. Unlike edge-lit, array-lit provides a more even, uniform, and brighter lighting. It can also implement "local dimming", in which the LEDs are grouped and can be individually turned on and off independently, which means that some areas can be dimmed while others remain illuminated. Local dimming helps improve the dynamic contrast ratio of the display by dimming the parts that should be dark, while illuminating the parts that should be bright.

### Incandescent Backlight

An incandescent lamp emits light when its filament is heated to a high temperature by an electric current passing through it. This backlighting method is rarely used except on applications where cost is a major consideration. This is due to its unsatisfactory performance in terms of display, life span, ruggedness, and power.

### Electroluminescent Backlight

Electroluminescence is the conversion of electrical energy into light energy by the flow of electrons, without any thermal energy or heat involved. Electroluminescent Lamps (EL) typically come in some type of panel arrangement, have the characteristics of being thin, lightweight, and can provide even light and high contrast. EL is basically a capacitor with an inorganic phosphor sandwiched between the electrodes. Since it is an AC device, it requires an inverter for power conversion. It is particularly implemented in applications using panels that have been segmented during the manufacturing process which can display static or animated images or logos.



## Cold Cathode Fluorescent Lamp (CCFL) Lamp

CCFL backlight is usually implemented in medium-sized to large-sized LCD. It is a lighting system that uses both electron discharge and fluorescence. CCFL is a gas discharge lamp which uses a phosphor material, typically mercury vapor, to emit ultraviolet light, which in turn causes the fluorescent coating or phosphor to emit visible light. CCFL offers low-power consumption and very bright full spectrum white light. It is usually employed in applications requiring high brightness and high contrast. One of its major disadvantages is poor performance in low-temperature environments.

## Fiber Optic Backlight

Fiber Optic Backlighting uses bulbs which are usually mounted away from the LCD panel. The type of bulb can be either incandescent lamp or LED, with the latter being the most common. The bulb provides illumination to sheets of fiber cloth to create the backlight of desired shapes, sizes and configurations. A few of the main advantages of fiber optic backlighting are more uniform light distribution, lower power consumption, and a wide range of color choices.

## LCD TECHNOLOGIES

Based on technology implementation, LCD is classified into two types: Passive and Active LCDs. This section provides a comparison between these two types and a brief discussion on their subtypes. [Table 3](#) provides a comparison between the features of Passive Matrix and Active Matrix LCDs.

**TABLE 3: PASSIVE VS. ACTIVE LCD**

Feature	Passive	Active
Response Time	Slower	Faster
Contrast	Poor	High
Viewing Angle	Limited	Better
Resolution	Lower	Higher
Cost	Cheap	Expensive
Hardware Implementation	Simple	Complex

## Passive Matrix LCD

A passive matrix LCD uses a grid of conductive material to supply charge to a particular pixel on the display. This type of display has the same basic construction with the one in [Figure 2](#). For the two glasses, one has rows of electrodes while the other has columns of electrodes. The intersection of these rows and columns forms a pixel. A pixel is ON when both row and column lines corresponding to this particular pixel are energized and OFF when both control lines are de-energized. When voltage is applied between these two points, the liquid crystal realigns which varies the direction of light propagation through the liquid crystal, resulting to a dark or ON pixel. Likewise, when there is no voltage between the two points, the liquid crystal return to its twisted state, resulting to a clear or OFF pixel.

One particular kind of nematic LCs is the **Twisted Nematic (TN)**, in which the rubbing directions in the two glass substrates are perpendicular to each other, creating a 90° twist of director from one substrate to the other (see [Figure 3](#)). The crossed polarizers' orientations are always parallel to the direction in which the polyimide is rubbed. When a voltage is applied, molecules align along the electric field and untwist to varying degrees, and with enough high field, the twist is removed and the light is completely blocked by the second polarizer, producing an ON pixel. When there is no voltage across the electrodes, the light passes unobstructed through the two polarizers, creating an OFF pixel.

The gray scale is achieved in TN displays by applying field strength somewhere in between the completely ON and completely OFF state. TN is primarily dependent on the response of the LC molecules to the applied voltage.

The optical performance of highly multiplexed TN LCDs has become impractical for large information displays due to its poor contrast, low brightness, and very strong viewing angle dependency. These requirements, however, were fulfilled with the invention of the **Super Twisted Nematic (STN)** LCDs. In this type of display, the molecules are twisted from 180° to 270°, producing a much steeper electro-optical threshold curves which put the ON and OFF voltages closer to each other. Steeper thresholds mean a significant increase in multiplex rates that can be achieved.

The **Film Compensated STN** is an enhanced version of the STN which was developed to produce sharper images, better contrast, and a wider viewing angle. In this type of display, a film optical filter is added between the STN display and the outer polarized filter. This technology is commonly utilized in early laptops, cellular phones, and other hand-held devices.

In contrast with the optical film used in the FSTN, **Double STN** technology utilizes two distinct STN filled glass cells to compensate light dispersion. The first glass is the LCD and the second is an inactive glass cell having no electrodes or polarizers, but only filled with LC. When this extra cell is activated, two distinct images can be produced and this technology is referred to as the **Double Active STN**. The response time of DSTN is significantly enhanced and it offers high brightness and contrast ratio, as compared with the STN and FSTN. It also has an extended operating temperature range of -30°C to 85°C, making it suitable for advanced automotive displays and some industrial applications.

Another type of passive matrix LCD is the **Color STN**, which is essentially a STN using a white backlight and red, green, and blue filters to produce a color display. Modern CSTN displays offer faster pixel response time, a larger viewing angle, and high quality color. It is also a viable alternative to active matrix LCDs when cost is a major consideration.

## Active Matrix

Active matrix LCDs basically depend on the Thin Film Transistor (TFT) technology. Tiny switching transistors and capacitors are arranged in a matrix on the display glass. To activate a particular pixel, the appropriate row is turned on while a charge is transmitted along the correct column. The capacitor on the designated pixel holds the charge until the next refresh cycle. Transistors allow the pixels to be switched ON and OFF at a very fast rate. TFTs also allow a precise control of voltage to create different levels of brightness per pixel. Time dependency in multiplexed displays is also eliminated since one transistor is allocated for each pixel. Many modern television sets, laptops, mobile phones, and other high-end displays make use of this technology.

## CONTRAST

The contrast of an LCD is dependent upon the amplitude of the driver voltages and the available ambient light. Overdriving the glass can result in a condition called **ghosting**, in which pixels that are supposed to be OFF appear to be ON. This usually occurs when too high drive voltage electric field influences adjacent pixels. Ghosting can also be caused by insufficient discrimination ratio and high viewing angle. High temperature is another factor which causes the LC to assume random orientation.

Sometimes, pixels that should be ON become barely visible. These **faint pixels** can be caused by insufficient discrimination ratio, too low drive voltage, and very low temperature. Hence, it is important to check the specifications provided by the LCD glass manufacturer to prevent damaging the glass. Table 4 shows an example of the LCD glass specifications implemented in Microchip's PICDEM™ LCD 2 Demo Board.

**TABLE 4: LCD GLASS SPECIFICATIONS**

Type	Specification
P.I.D	VL_5573_V00
Mode/Color/Type	Positive/--/TN
Viewing Direction	6:00 Clock
Driving Scheme	1/4 Duty, 1/3 Bias
Drive Voltage (VLCD)	~3.0 Volt (p-p), +20°C
Operating Temperature	0°C-+50°C
Storage Temperature	-10°C-+60°C
Polarizer-Front	STD. Transmissive
Polarizer-Back	STD Reflective

The specifications shown in the table and their effects on contrast will be discussed in more detail in the succeeding sections.

## DRIVER VOLTAGES

The number one cause of LCD damage is having a DC voltage applied to it. A DC voltage will deteriorate the LC fluid such that it cannot be energized. The LCD driver waveforms are designed to create a 0 Vdc potential across all pixels. The specifications for an LCD panel will include some RMS voltages such as  $V_{OFF}$  and  $V_{ON}$ . A third voltage is  $V_{TH}$  which is the RMS voltage across an LCD pixel when contrast reaches a 10% level. Often, this voltage is used as  $V_{OFF}$ .  $V_{ON}$  is defined as the RMS voltage applied by the LCD driver to the segment electrode that creates an ON pixel which is typically at the 90% contrast level.

Figure 13 graphically represents the voltage potential versus the contrast across a pixel. Another specification for an LCD panel is the discrimination ratio which identifies what type of contrast levels the

LCD panel will be able to achieve. Examples of discrimination ratio calculations are given in the Section "Discrimination Ratio".

**FIGURE 13: CONTRAST vs. RMS VOLTAGE**

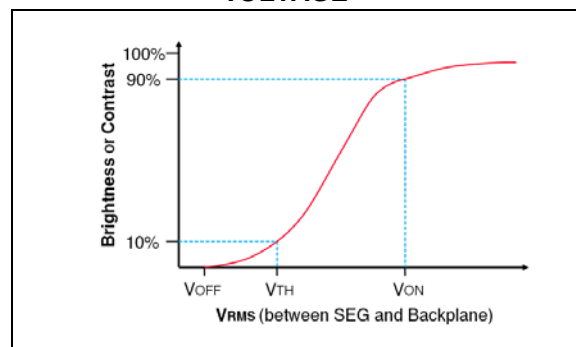

## RESPONSE TIME

An LCD panel will have a typical ON and OFF response time. The ON time parameter refers to the time for an OFF pixel to become visible after the appropriate voltages have been applied. The OFF time parameter specifies the time for an ON segment to disappear. Sometimes, these parameters are called "rise" and "decay", respectively. Typically, the OFF time is somewhat larger than the ON time because the LC takes time to return to its untwisted state, unlike when it is being turned ON in which force is being involved.

Temperature plays a key role in the response time of an LCD panel. Figure 14 shows the response time versus temperature for commercial type LC fluid. LCD panels are usually incorporated with heaters in very cold locations due to the significant increase in response time as the temperature drops below 0°C. Displays with heaters, however, have the disadvantage of consuming more power.

**FIGURE 14: RESPONSE TIME vs. TEMPERATURE**

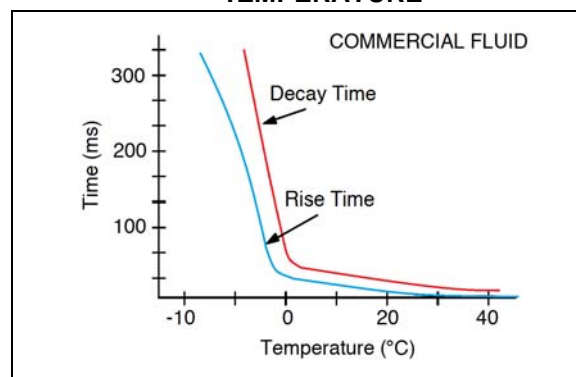

## TEMPERATURE EFFECTS

As previously shown, temperature has a large impact on the performance of the LCD panel. Not only is the LC fluid affected, but the internal coatings begin to deteriorate. All LC fluids have well defined operating temperature limits. If an LCD is operated above its fluid limits, the LC molecules begin to assume random orientations. The pixels on a positive image display will become completely dark, while pixels on a negative image display will become completely transparent. An LCD can recover from these conditions if the exposure is kept short. However, temperatures above 110°C will cause the ITO and polyimide coatings to deteriorate.

On the low end of the temperature spectrum, response time increases because the viscosity of the LC fluid increases. At very low temperatures, typically -60°C, the LC fluid transitions into a crystalline state. Usually, the LC fluid can recover from the effects of low temperature. Many different types of LC fluid are available, which allows the LCD panel to be tailored to

the expected operating conditions. As mentioned in the previous section, heaters can combat the effects of low temperature.

## CAPACITANCE

The LCD panel can be modeled as a lossy, non-linear capacitor. The area of the pixel, and therefore the size of the LCD panel, has a direct impact on the value of the capacitance that a common or segment driver must be able to drive. Typical values of capacitance are in the range of 1000 - 1500 pF/cm<sup>2</sup>. Figure 15 shows an example of a 1/3 MUX panel. The common driver must be capable of driving significantly higher capacitances than the segment driver.

Care must be taken when designing a system such that the LCD driver is capable of driving the capacitance on the segment and common. Otherwise, the LCD panel may be damaged due to a DC offset voltage generated by overloaded segment and common drivers.

**FIGURE 15: 1/3 MUX EQUIVALENT CIRCUIT**

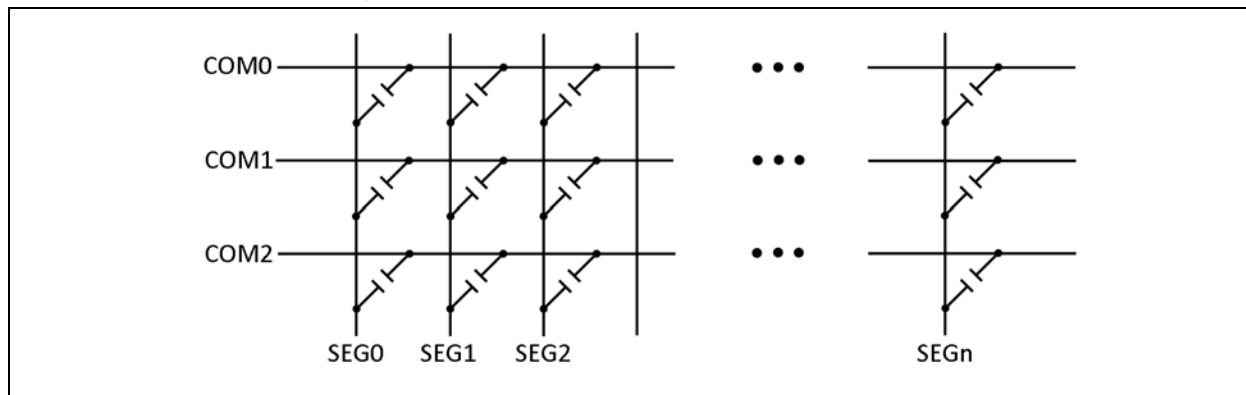

## STATIC vs. MULTIPLEX DRIVE

LCD panels come in many varieties depending on the application and the operating environment. LCDs can be classified in two ways. First of all, LCDs come in direct drive or multiplex drive variations. Direct drive, otherwise known as static, means that each pixel of the LCD panel has an independent driver. The LCD panel also has only one common. A static drive panel also has static bias. Bias is defined as the number of voltage levels the LCD driver uses to create images on the screen. The number of voltage levels is equivalent to  $1 + 1/\text{bias}$ . Static bias refers to two voltage levels which create a square wave: ground and V<sub>DD</sub>. Static drive panels also have the best contrast ratios over the widest temperature range.

Multiplex drive panels reduce the overall amount of interconnections between the LCD and the drive. Put simply, multiplex panels have more than one common. A multiplex LCD driver produces an amplitude-varying, time synchronized waveform for both the segment and commons. These waveforms allow access to one pixel on each of the commons. This significantly increases the complexity of the driver. The number of commons,

a panel, has this referred to as the multiplexing ratio or the “MUX” of the panel. MUX also refers to duty cycle. For instance, a 1/3 MUX panel has three commons. The bias for multiplex panels is at least 1/2—1/5 for segment type drivers and from 1/8—1/33 for dot matrix. [Table 5](#) illustrates the advantage of multiplex panels.

**TABLE 5: STATIC VS. MULTIPLEX PIN COUNT**

LCD Panel	Pins		
	Commons	Segments	Total
3 -1/2 Digit	1	23	24
	2	12	14
8 Digits	1	64	65
	4	16	20
2 x 16 Character Dot Matrix, 5 x 7 Characters	1	1280	1281
	8	160	168
128 x 240 Graphic Display	16	80	96
	64	480	544
	128	240	368

[Table A-1](#) of [Appendix A: “8-Bit MCU with Integrated LCD Controllers”](#) shows the drive capabilities of different 8-bit PIC MCUs with integrated LCD controller. The multiplex type and bias depend upon the LCD glass specifications provided by the manufacturer. For example, the PICDEM™ LCD 2 glass should be driven with 1/4 MUX and 1/3 Bias, while 1/8 MUX and 1/3 Bias for the LCD Explorer glass.

## TYPES OF DISPLAY NOTATION

The other method of classifying LCD panels is the type of display notation used.

### Segment Displays

Segment Displays are usually the 7-segment, 14-segment, or 16-segment (“British Flag”) types used to create numbers and letters. These types of display are usually static driven which provides the best contrast and readability in sunlight. [Figure 16](#) shows all three segment displays mentioned. Typical applications of segment displays are in calculators, digital clocks, gas station pump readouts, and other displays which do not require much detail.

**FIGURE 16: SEGMENT TYPE DISPLAY**

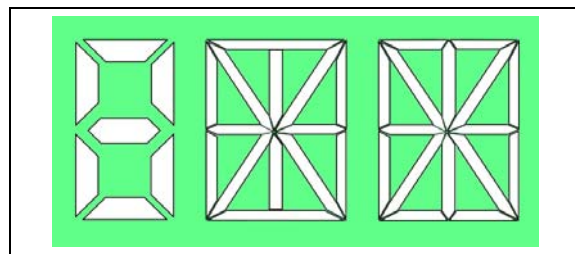

### Dot Matrix

Dot matrix displays are always multiplex type displays due to the large number of pixels required and pin limitations on the driver. Dot matrix displays can create more natural letters and numbers, as well as custom graphic symbols. [Figure 17](#) shows a typical 5x7 dot matrix character set.

## Function Indicator or Icon

The third type of display is most commonly used in conjunction with the previous types. A function indicator or icon provides status information about the system. They are only capable of being turned on or off. One example would be a digital multimeter. The meter has three 1/2 digits which are 7-segment type and also some icons for volts, amps, ohms and the ranges for m,  $\mu$ , K, and M.

Microchip's PICDEM™ LCD 2 Demonstration Board has a built-in LCD glass which can display both segment and functional displays. Figure 18 shows the display layout of this custom-made glass manufactured by the Varitronix Corporation. Refer to Table 4 for the LCD glass specifications.

The LCD Explorer Demonstration Board, Microchip's latest 8-Common LCD board for evaluation of the PIC24F and PIC18F LCD devices, includes an 8-Common LCD glass that displays both the dot matrix and various function indicators as shown in Figure 19.

**FIGURE 17: 5 x 7 DOT MATRIX DISPLAY**

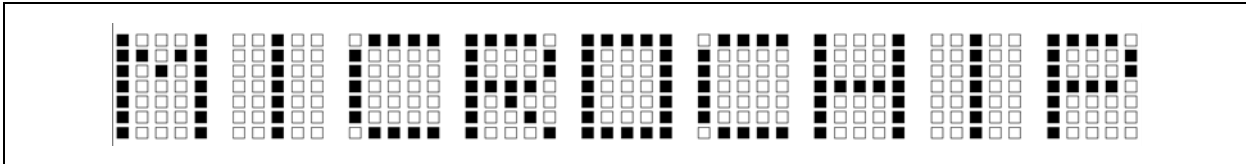

**FIGURE 18: PICDEM™ LCD 2 GLASS DISPLAY**

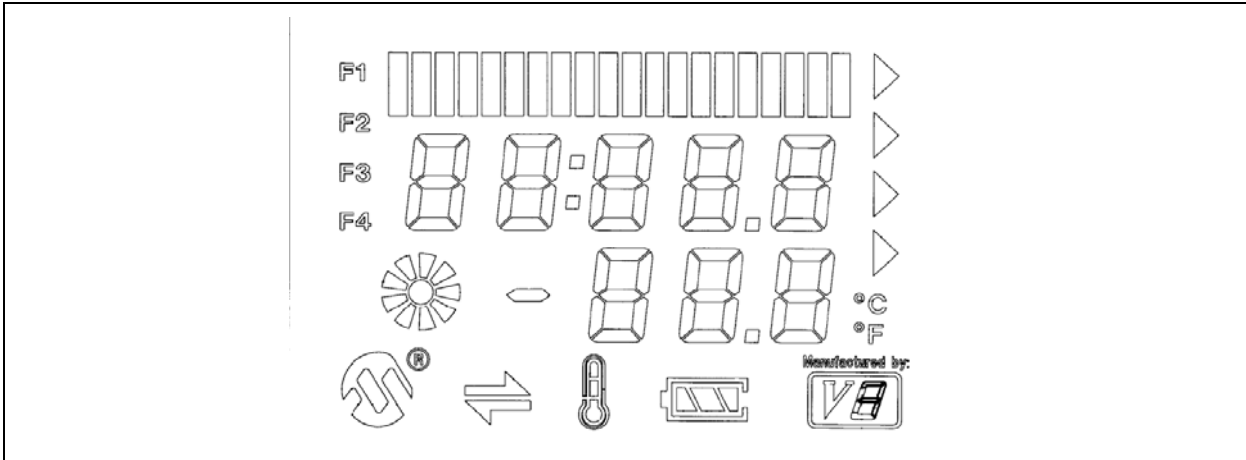

**FIGURE 19: LCD EXPLORER GLASS DISPLAY**

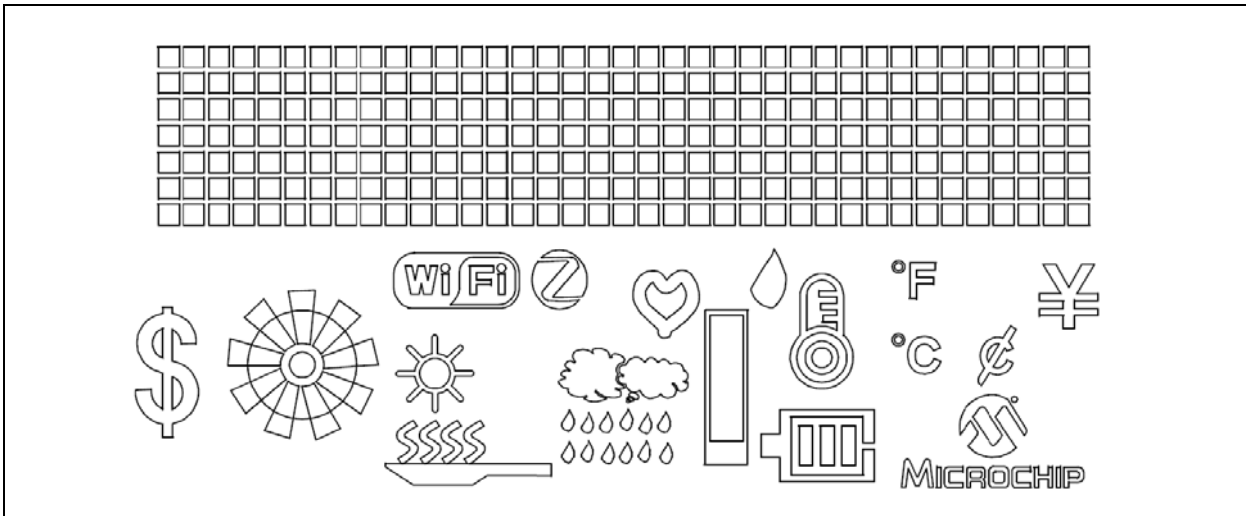

## LCD VIEWING ANGLE

The LCD viewing angle is usually specified in the glass manufacturer's data sheet. It is a term used frequently when referring to an LCD display, but its definition is often confused with the meaning of bias angle. Bias angle is the angle from the perpendicular from which the display is best viewed, and is always set during the

manufacturing process. Its orientation is usually specified with reference to a clock face. An offset above the display is referred to as "12:00" or "top" view, whereas an offset below the display is referred to as "6:00" or "bottom" view. Viewing angle, on the other hand, is the angle formed on either side of the bias angle, in which the contrast of the display is still considered acceptable.

**FIGURE 20: LCD VIEWING ANGLE**

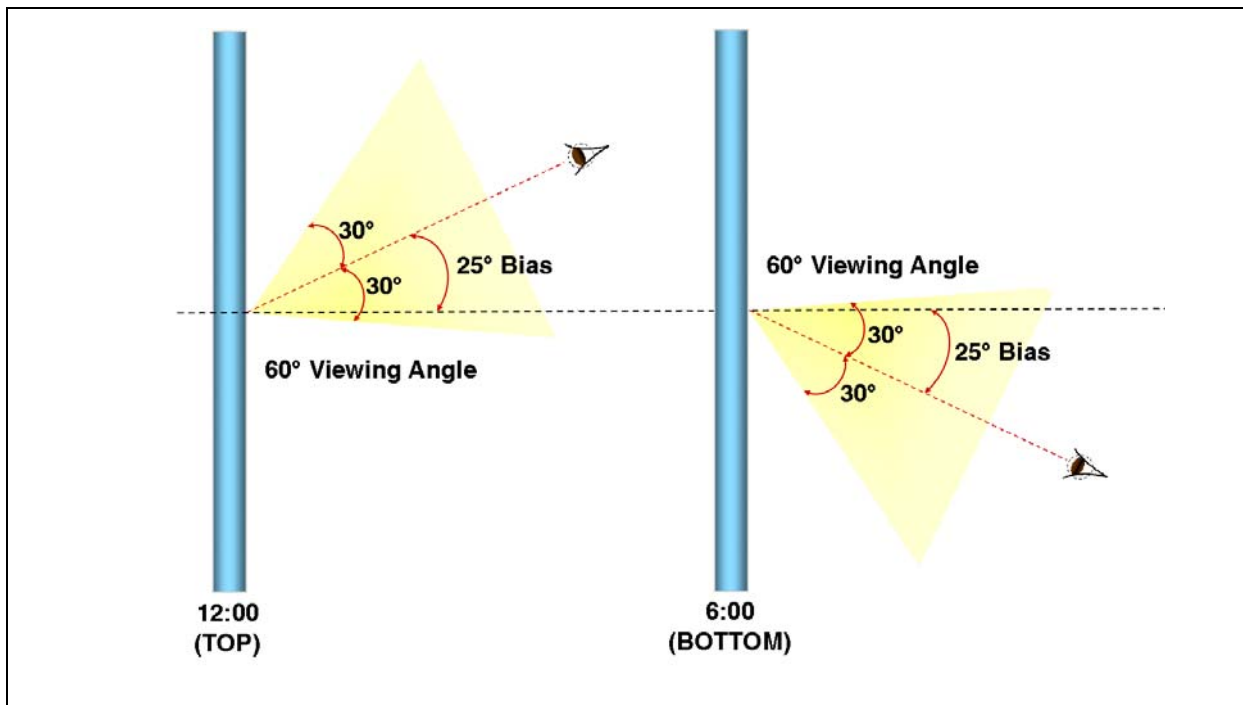

Figure 20 shows the LCD viewing angles for both the 12:00 and 6:00 views. For the 12:00 view, the observer can view the best contrast when looking towards the display at  $25^\circ$  above the horizontal, which is the bias angle. When moving the eye further  $30^\circ$  above or below this reference, the display can still be viewed, however, with reduced contrast. Moving the eye any further exceeding the  $60^\circ$  viewing angle will reduce the contrast to an undesirable level. This same basic principle applies for a display at 6:00 view, in which the bias angle is below the horizontal.

The choice of viewing position depends upon the application of the LCD. Devices that rest on the tabletop, such as calculators are usually viewed from below. A 6:00 module should be employed for such applications. For displays that are usually viewed from the top, such as the ones installed on the dashboard of a vehicle, a 12:00 module is more preferable.

**CONNECTION METHODS**

**Dual In-Line Pins**

The earliest method of connecting the LCD panel to external interface was the dual-in-line pin shown in Figure 21. These pins provide excellent protection from harsh environments, vibration or shock. The LCD panel is either soldered directly to the printed circuit board (PCB) or inserted into headers.

**FIGURE 21: DUAL IN-LINE PINS**

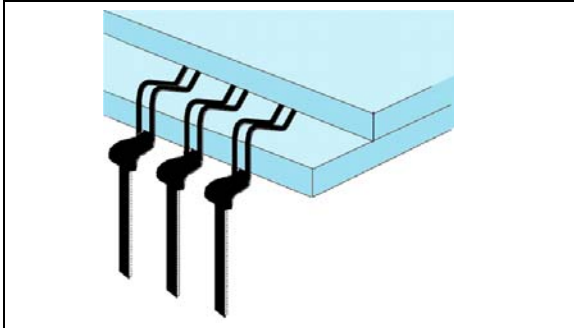

**Elastometric Connectors**

This method allows fast assembly/disassembly without having to solder the LCD panel. Elastometric connectors are used on small applications where space is a concern. These connectors are relatively resistant to shock and vibration, but special

consideration must be used when the panel will be exposed to harsh environments. Figure 22 shows an assembly drawing of an elastometric connector.

**FIGURE 22: ELASTOMETRIC CONNECTORS**

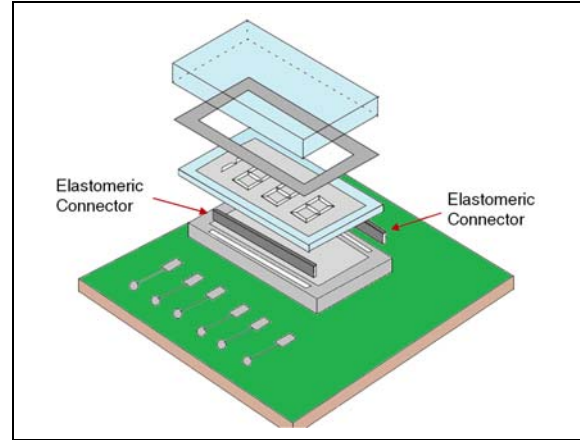

**Flex Connectors**

In this method, a PCB and the LCD panel are connected by a flexible cable using a heat seal process. The flexible cable is typically an anisotropic connective film that is applied to the PCB and the LCD panel using heat and pressure. These connectors were designed for harsh environments where the connector must be flexible enough to prevent breakage during stress. These connectors are becoming more popular with large or remotely mounted LCD panels. Figure 23 shows a typical application.

**FIGURE 23: FLEX CONNECTORS**

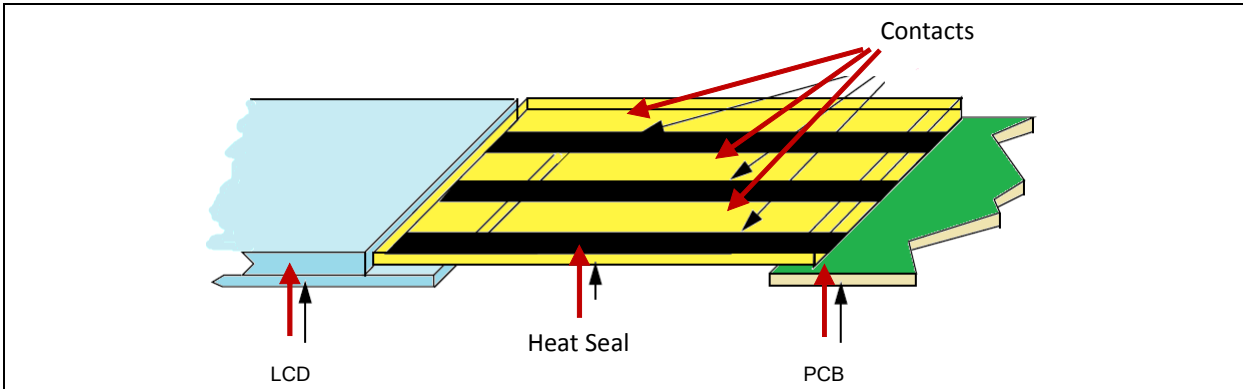



## THE LCD DRIVER MODULE

Microchip offers a wide range of 8-bit PIC microcontrollers with integrated LCD controllers. These devices can directly drive segmented displays with letters, numbers, characters, and icons, and are developed to meet the low-power design requirements. Available in 28-, 40-, 64-, 80-, and 100-pin packages,

PIC microcontrollers offer not only flexibility and ease in LCD interfacing and control, but also cut design cost by eliminating the need for several external hardware components. [Table A-1 of Appendix A: “8-Bit MCU with Integrated LCD Controllers”](#) provides a summary of the features of the LCD driver module of some common 8-bit PIC MCUs. Refer to this table from time to time for the subsequent sections.

**FIGURE 24: LCD MODULE BLOCK DIAGRAM**

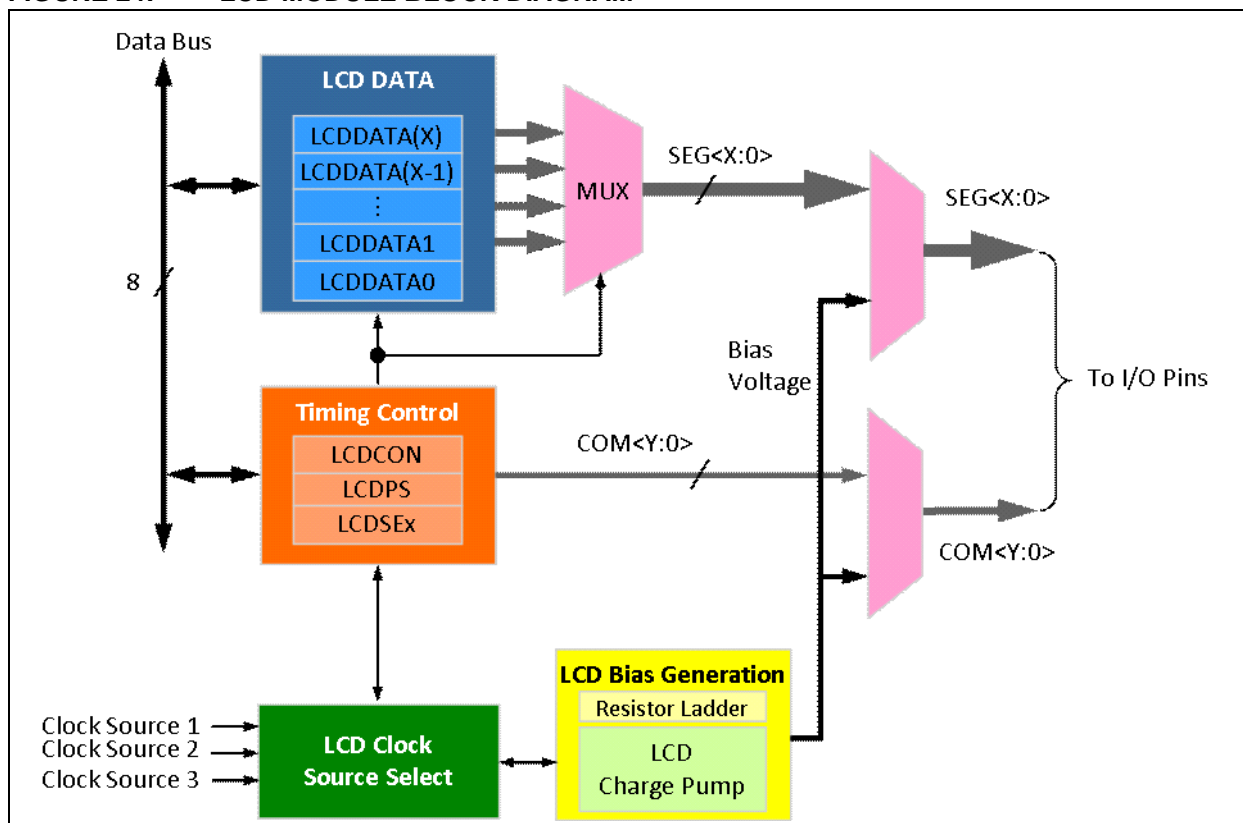

The LCD driver module generates the timing control to drive a static or multiplexed LCD panel, with support for up to 64 segments multiplexed with up to four commons for some PIC16 devices, such as the PIC16F1946 and PIC19F1947, and up to 64 segments multiplexed with eight commons for latest PIC18 devices, such as the PIC18F97J94. [Figure 24](#) shows a typical LCD module block diagram for 8-bit PIC microcontrollers.

## LCD REGISTERS

The number of LCD registers varies depending upon the maximum number of commons and segments that can be driven by the specific device used. The web links for the data sheets of PIC devices mentioned in this application note are provided on [Table F-1 of Appendix F: “References and Related Documents”](#) for easy reference. To avoid complexity, this section explains the different LCD registers, block-by-block, as shown in [Figure 24](#). As mentioned earlier, the figure only applies to the new PIC devices. Some of the blocks may not be present in the older parts.

## Timing Control Block

As shown in [Figure 24](#), the Timing Control block is composed of the following registers:

- LCD Control Register (LCDCON)
- LCD Phase Register (LCDPS)
- LCD Segment Enable Registers (LCDSEx:LCDSE0)

The LCDCON register controls the overall operation of the module. Once the module is configured, the LCDEN (LCDCON<7>) bit is used to enable or disable the LCD module. The LCD panel can also operate during Sleep by clearing the SLPEN (LCDCON<6>) bit. The (CS<1:0>) bits determine the LCD clock source, which is discussed in detail on the [Section “LCD Clock Sources”](#). LMUX<1:0> (for 4-common devices) or LMUX<2:0> (for 8-common devices) bits define the number of commons used in the application. Take note that the configuration must comply with the LCD glass driving scheme specifications.

The LCDPS register configures the LCD clock source prescaler, and the type of waveform: Type-A (WFT = 0) or Type-B (WFT = 1). An in-depth discussion between these two waveforms is presented in the [Section “LCD Waveforms”](#). The Prescaler Select (LP<3:0>) bits have a direct effect on the LCD frame frequency, so it must be set accordingly to avoid ghosting or flickering of the display. The [Section “LCD Frame Frequency”](#) provides more information regarding frame frequency limits and computation.

The LCDSEx configure the functions of the port pins. Setting the segment enable bit for a particular segment configures that pin as an LCD driver. Likewise, clearing the segment enable bit allows the pin to function as an I/O port. The number of LCDSE registers varies per device. For example, PIC18F97J94 has eight LCDSE registers and can drive up to 64 segments (SE<63:0>). [Table 6](#) shows the corresponding segments that can be set by each bit of the LCDSEx registers (LCDSE7:LCDSE0).

**TABLE 6: LCDSEx REGISTERS AND ASSOCIATED SEGMENTS**

Register	n	Segment							
		Bit 7	Bit 6	Bit 5	Bit 4	Bit 3	Bit 2	Bit 1	Bit 0
		SE(n+7)	SE(n+6)	SE(n+5)	SE(n+4)	SE(n+3)	SE(n+2)	SE(n+1)	SE(n)
LCDSE0	0	7	6	5	4	3	2	1	0
LCDSE1	8	15	14	13	12	11	10	9	8
LCDSE2	16	23	22	21	20	19	18	17	16
LCDSE3	24	31	30	29	28	27	26	25	24
LCDSE4	32	39	38	37	36	35	34	33	32
LCDSE5	40	47	46	45	44	43	42	41	40
LCDSE6	48	55	54	53	52	51	50	49	48
LCDSE7	56	63	62	61	60	59	58	57	56

## LCD Data Block

Like the Timing Control block, the LCD DATA block in [Figure 24](#) is also present in all PIC MCU LCD modules. It is composed of the LCDDATAx registers.

After the module is initialized for the LCD panel, the individual bits of the LCDDATAx registers are cleared or set to represent a clear or dark pixel, respectively.

Specific sets of LCDDATA registers are used with specific segments and common signals. Each bit represents a unique combination of a specific segment connected to a specific common.

Individual LCDDATA bits are named by the convention, “SxxCy”, with “xx” as the segment number and “y” as the common number. An example of SEG and COM combinations is shown in [Table 7](#) for the PIC18F97J94 which has 64 LCDDATA registers (LCDDATA63:LCDDATA0).

To understand more about these common and segments combination, a simple example is presented in the [Section “LCD Segment Mapping”](#).

**TABLE 7: LCD DATA REGISTERS AND BITS FOR SEGMENT AND COM COMBINATIONS**

COM Lines	Segments							
	0 to 7	8 to 15	16 to 23	24 to 31	32 to 39	40 to 47	48 to 55	56 to 63
0	LCDDATA0 S00C0:S07C0	LCDDATA1 S08C0:S15C0	LCDDATA2 S16C0:S23C0	LCDDATA3 S24C0:S31C0	LCDDATA4 S32C0:S39C0	LCDDATA5 S40C0:S47C0	LCDDATA6 S48C0:S55C0	LCDDATA7 S56C0:S63C0
1	LCDDATA8 S00C1:S07C1	LCDDATA9 S08C1:S15C1	LCDDATA10 S16C1:S23C1	LCDDATA11 S24C1:S31C1	LCDDATA12 S32C1:S39C1	LCDDATA13 S40C1:S47C1	LCDDATA14 S48C1:S55C1	LCDDATA15 S56C1:S63C1
2	LCDDATA16 S00C2:S07C2	LCDDATA17 S08C2:S15C2	LCDDATA18 S16C2:S23C2	LCDDATA19 S24C2:S31C2	LCDDATA20 S32C2:S39C2	LCDDATA21 S40C2:S47C2	LCDDATA22 S48C2:S55C2	LCDDATA23 S56C2:S63C2
3	LCDDATA24 S00C3:S07C3	LCDDATA25 S08C3:S15C3	LCDDATA26 S16C3:S23C3	LCDDATA27 S24C3:S31C3	LCDDATA28 S32C3:S39C3	LCDDATA29 S40C3:S47C3	LCDDATA30 S48C3:S55C3	LCDDATA31 S56C3:S63C3
4	LCDDATA32 S00C4:S07C4	LCDDATA33 S08C4:S15C4	LCDDATA34 S16C4:S23C4	LCDDATA35 S24C4:S31C4	LCDDAT36 S32C4:S39C4	LCDDATA37 S40C4:S47C4	LCDDATA38 S48C4:S55C4	LCDDATA39 S56C4:S63C4
5	LCDDATA40 S00C5:S07C5	LCDDATA41 S08C5:S15C5	LCDDATA42 S16C5:S23C5	LCDDATA43 S24C5:S31C5	LCDDATA44 S32C5:S39C5	LCDDATA45 S40C5:S47C5	LCDDATA46 S48C5:S55C5	LCDDATA47 S56C5:S63C5
6	LCDDATA48 S00C6:S07C6	LCDDATA49 S08C6:S15C6	LCDDATA50 S16C6:S23C6	LCDDATA51 S24C6:S31C6	LCDDATA52 S32C6:S39C6	LCDDATA53 S40C6:S47C6	LCDDATA54 S48C6:S55C6	LCDDATA55 S56C6:S63C6
7	LCDDATA56 S00C7:S07C7	LCDDATA57 S08C7:S15C7	LCDDATA58 S16C7:S23C7	LCDDATA59 S24C7:S31C7	LCDDATA60 S32C7:S39C7	LCDDATA61 S40C7:S47C7	LCDDATA62 S48C7:S55C7	LCDDATA63 S56C7:S63C7

### LCD Bias Generation Block

In general, there are two methods of generating the bias voltages: resistor ladder and charge pump. These two can be either externally or internally supported by the device. Early PIC microcontrollers supported only external biasing, but newer ones can support both.

The LCDREF register determines what type of resistor biasing is used: external or internal. Setting the LCDIRE (LCDREF<7>) bit enables internal biasing. The [Section “LCD Biasing Methods”](#) provides more information on the pros and cons of external and internal biasing. When internal reference is enabled (LCDIRE = 1), contrast can be software controlled by configuring the LCDCST<2:0> bits. These bits can be found in a separate register (LCDCST register) for some devices. The power source of the contrast control circuit can be selected through the LCDIRS (LCDREF<6>) bit. The LCDREF register also determines which bias pins are used internally or externally for the different bias levels.

The LCDRL register provides control for the different Ladder Power modes, as well as the time interval for each power mode. These power modes are discussed in more detail in the [Section “Power Modes”](#).

Using the charge pump method requires only one register to be configured, the LCDREG register. This method is supported by PIC18 devices, such as the PIC18F97J94 and the PIC18F87J90 families. When the charge pump is enabled (CPEN = 1), contrast can be controlled through the BIAS<2:0> (LCDREG<5:3>) bits. The regulator supports either 1/3 or static bias by setting or clearing the MODE13 bit, respectively. The regulator also has to be provided with its own clock source through the CLKSEL<1:0> bits.

## LCD FRAME FREQUENCY

The LCD frame frequency is the rate at which the common and segment outputs change. [Table 8](#) shows the typical frame frequency formulas of 8-bit PIC MCUs for each multiplex type.

**TABLE 8: LCD FRAME FREQUENCY**

Multiplex	LMUX<2:0>	Frame Frequency =
Static	'000'	Clock Source/(4 x 1 x (LP<3:0> + 1))
1/2	'001'	Clock Source/(2 x 2 x (LP<3:0> + 1))
1/3	'010'	Clock Source/(1 x 3 x (LP<3:0> + 1))
1/4	'011'	Clock Source/(1 x 4 x (LP<3:0> + 1))
1/5	'100'	Clock Source/(1 x 5 x (LP<3:0> + 1))
1/6	'101'	Clock Source/(1 x 6 x (LP<3:0> + 1))
1/7	'110'	Clock Source/(1 x 7 x (LP<3:0> + 1))
1/8	'111'	Clock Source/(1 x 8 x (LP<3:0> + 1))

The clock source depends upon the configured Clock Source Select bits (CS<1:0>) on the specific device used. PIC MCUs typically have three clock source choices for the LCD module. This will be discussed in more detail in the [Section "LCD Clock Sources"](#).

The range of frame frequencies is from 25 to 250 Hz with the most common being between 50 to 150 Hz. Higher frequencies above 25 Hz result in higher power consumption and ghosting while lower frequencies below 25 Hz can cause flicker in the images on the LCD panel.

## LCD CLOCK SOURCES

The LCD module of 8-bit PIC MCUs has three possible clock sources: the Fast Internal RC (FRC) Oscillator, the Secondary Oscillator (SOSC), and the internal LPRC Oscillator. For some devices, the clock sources are the System Clock (FOSC/4), the Timer1 Oscillator (T1OSC), and the Internal RC Oscillator (LF-INTOSC). [Figure 25](#) shows a typical diagram on how a clock is being generated for the LCD peripheral.

For the three clock sources, a divider ratio is utilized to provide about 1 kHz output. For example, if the clock source is an 8 MHz Fast Internal RC (FRC) Oscillator, it has to be divided by 8192 to produce approximately 1 kHz output. This divider is not programmable. Instead, the LCD prescaler bits, LP<3:0> of the LCDPS register, are used to set the frame clock rate. These bits determine the prescaler assignment and prescaler ratio.

[Table B-1](#) of [Appendix B: "LCD Clock Sources"](#) shows a summary of the LCD clock sources and divider ratios, as well as the Sleep mode operation of these clock sources. Typically, two of these three clock sources may be used discretely to continue running the LCD while the processor is in Sleep. These clock sources are selected through bits CS<1:0>.

FIGURE 25: LCD CLOCK GENERATION

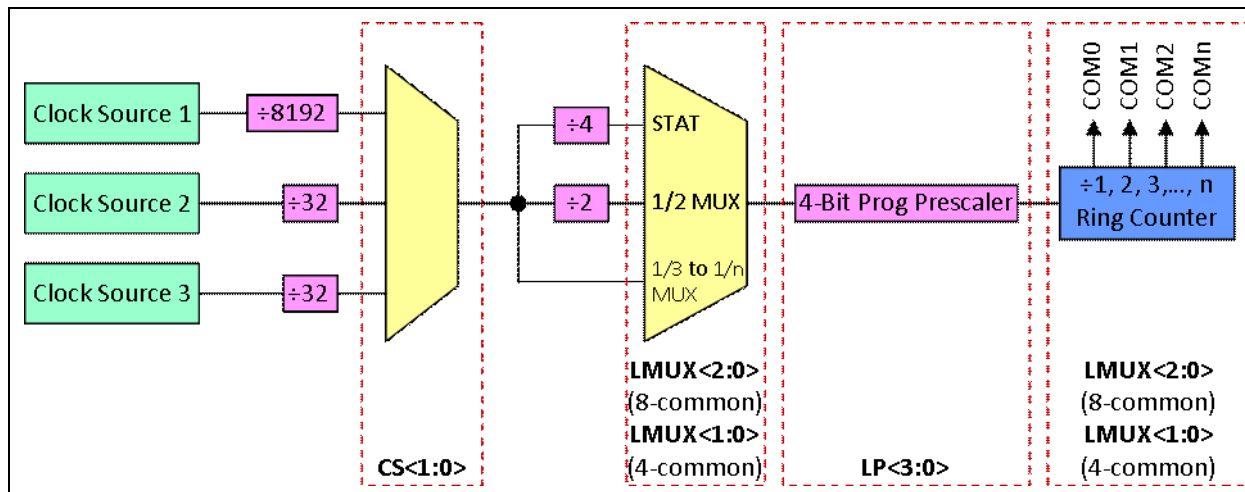

## LCD WAVEFORMS

An LCD can be characterized by the MUX ratio and bias, but one piece of information is still missing – Drive Waveforms. LCD waveforms are generated so that the net AC voltage across the dark pixel should be maximized and the net AC voltage across the clear pixel should be minimized. As mentioned earlier, the net DC voltage across any pixel should be zero. LCDs can be driven by two types of waveforms: Type A and Type B.

In a Type-A waveform, the phase changes within each common type, whereas a Type-B waveform's phase changes on each frame boundary. Thus, Type-A waveforms maintain 0 VDC over a single frame, whereas Type-B waveforms take two frames.

Typically, PIC microcontrollers can support both the Type-A and Type-B waveforms. Figure 26 shows both types of waveforms for 1/3 MUX and 1/3 Bias.

FIGURE 26: TYPE-A vs. TYPE-B WAVEFORMS

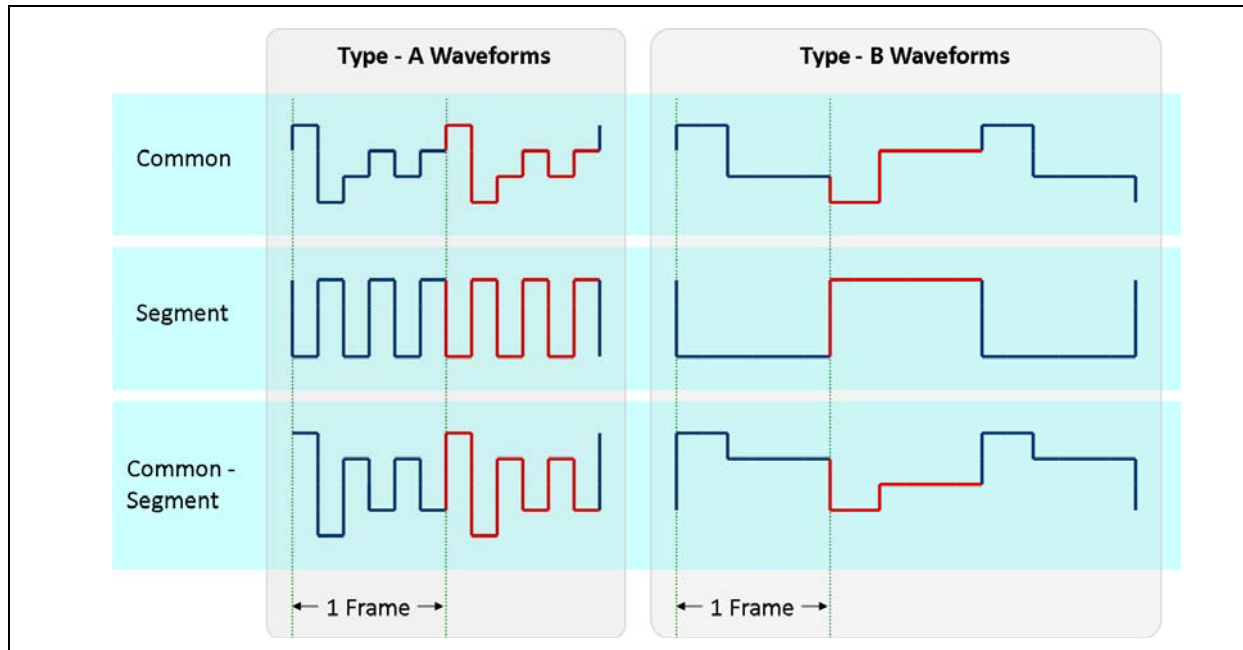

The voltage applied across a particular pixel is the voltage on the COM pin minus the voltage on the SEG pin (COMx-SEGx). If the resulting voltage is at or above the  $V_{ON}$  threshold, then the pixel is visible. If the voltage is at or below the  $V_{OFF}$  threshold, then the pixel will not be visible. This formula is used for all drive/bias methods.

PIC MCUs such as the PIC18F97J94 have 8-commons and also support both type of waveforms. This PIC18F97J94 is used for the following examples. [Figure 27](#), [Figure 28](#), and [Figure 29](#) provide waveforms for static, Type-A 1/8 MUX, and Type-B 1/8 MUX, respectively.

Type-A and Type-B waveforms are the same in static drive, as shown in [Figure 27](#). They also have two voltage levels that alternate within a single frame.

[Figure 28](#) is an example of a Type-A waveform in 1/8 MUX, 1/3 Bias Drive. For this waveform, a single frame consists of 16 time slices that correspond to twice the multiplex number. Since the waveform is a 1/3 bias drive, four voltage levels are possible for each time slice. See [Section "LCD Bias Types"](#) for the number of voltage levels for each bias type.

A Type-B waveform in 1/8 MUX, 1/3 Bias Drive is shown in [Figure 29](#). For this example, a single frame consists of eight time slices which is equal to the multiplex number. Each time slice also has four possible voltage levels.

The differences between these LCD waveforms in terms of display contrast will be discussed in the next section.

FIGURE 27: TYPE-A/TYPE-B WAVEFORMS IN STATIC DRIVE

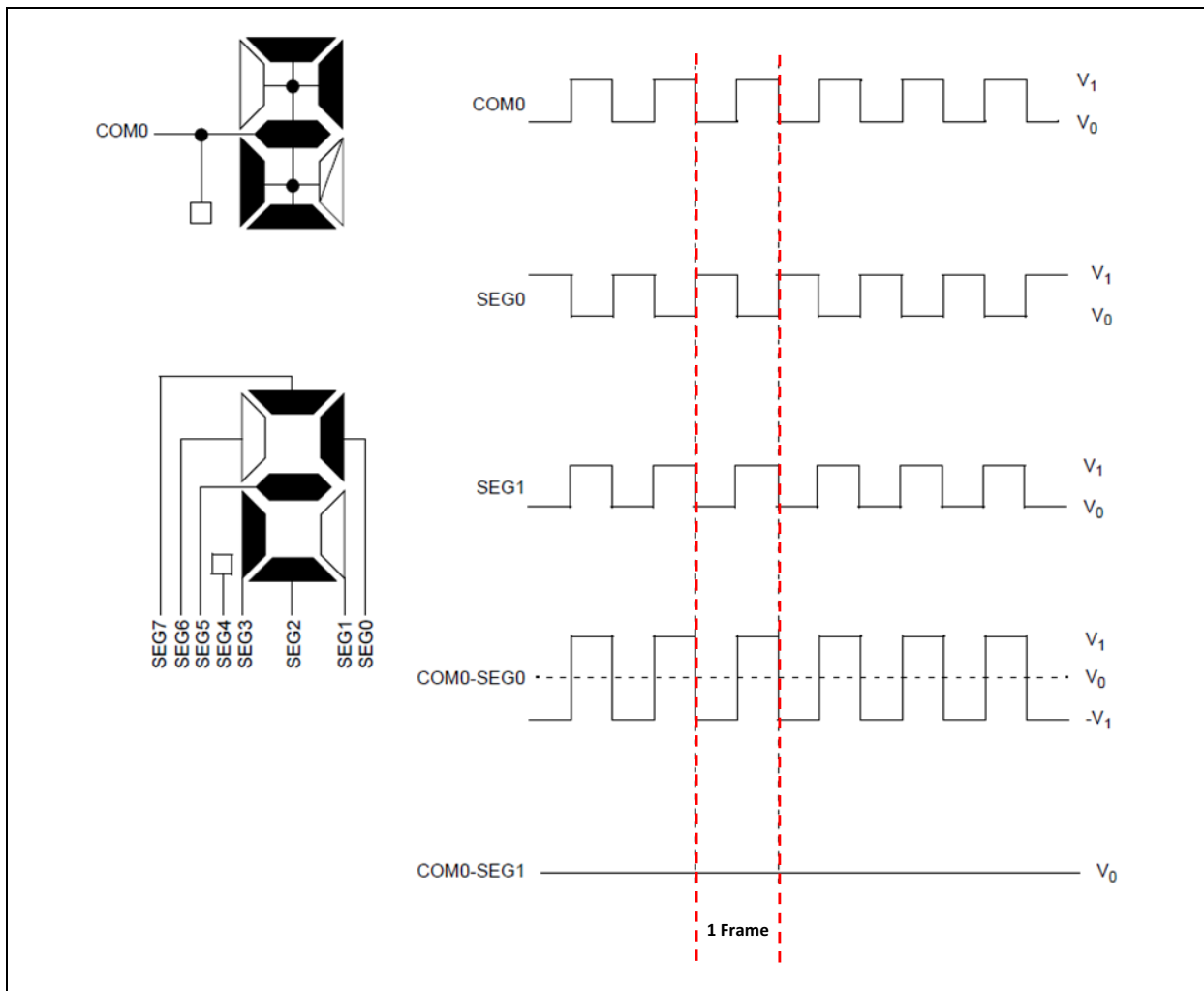

FIGURE 28: TYPE-A WAVEFORMS IN 1/8 MUX, 1/3 BIAS DRIVE

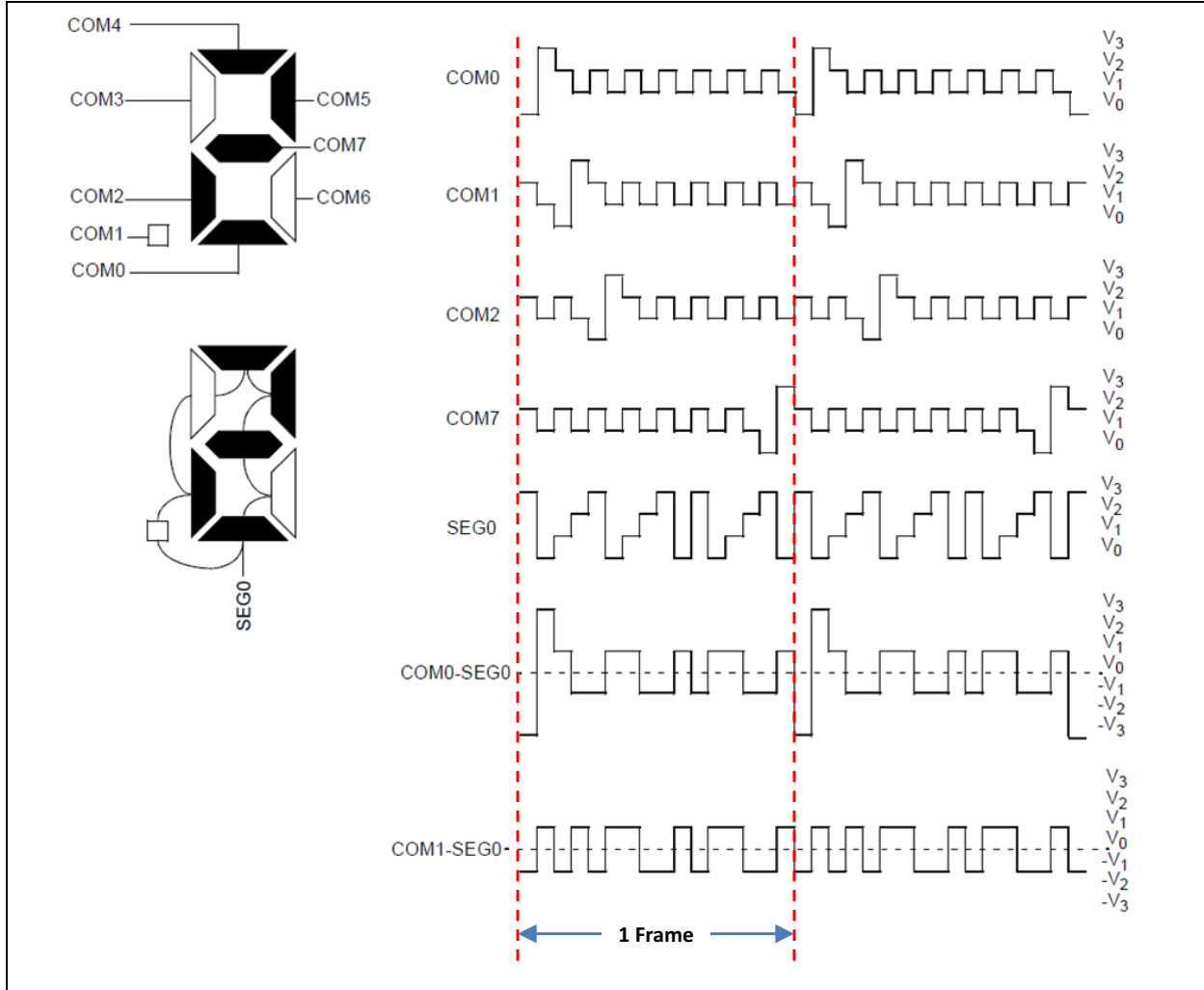
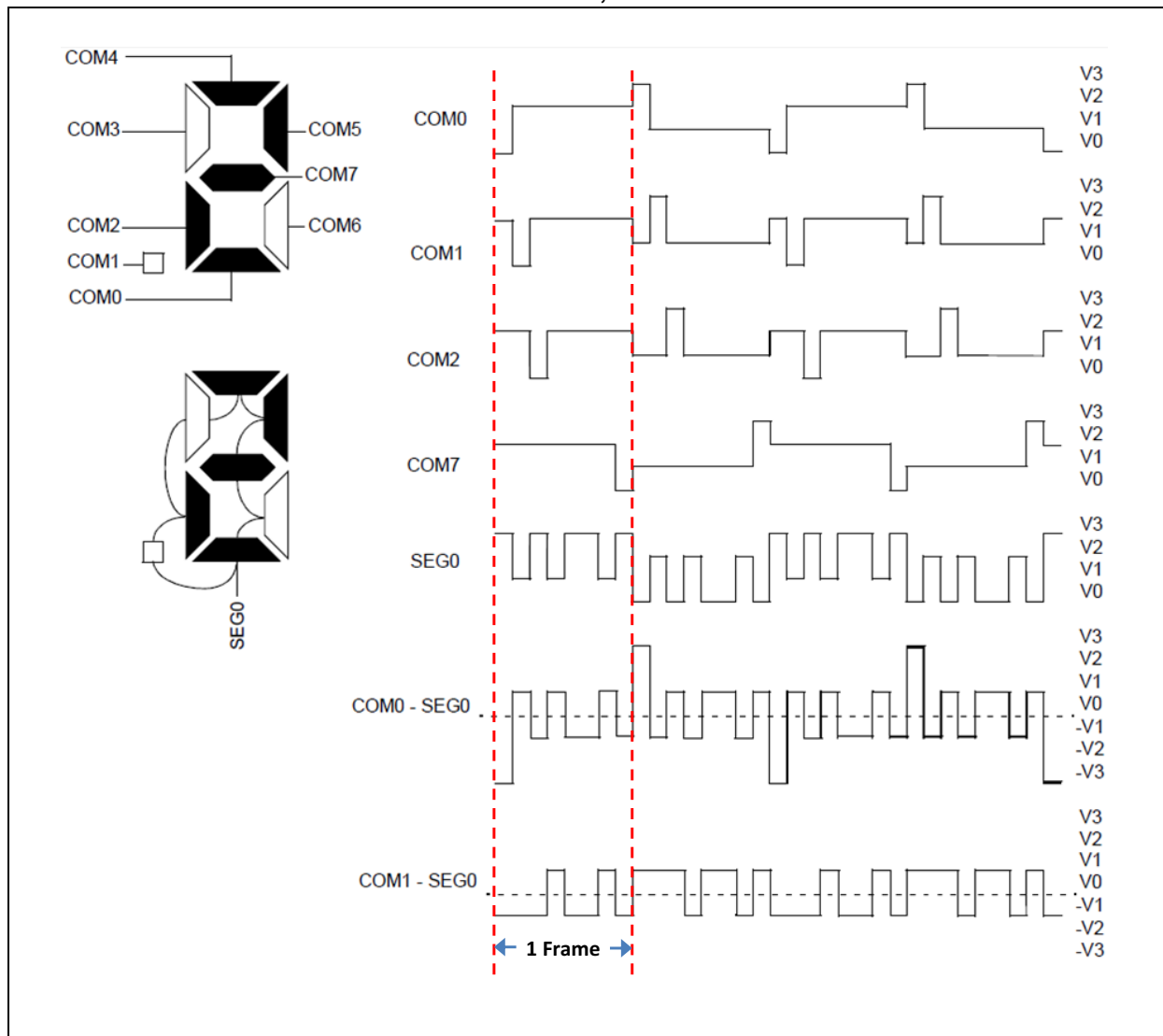



FIGURE 29: TYPE-B WAVEFORMS IN 1/8 MUX, 1/3 BIAS DRIVE



## DISCRIMINATION RATIO

The contrast of an LCD can be determined by calculating the discrimination ratio. Discrimination ratio ( $D$ ) is simply the ratio between the RMS voltage of an ON pixel with the RMS voltage of an OFF pixel, as defined by Equation 1.

### EQUATION 1: DISCRIMINATION RATIO EQUATION

$$D = \frac{V_{RMS} [ON]}{V_{RMS} [OFF]}$$

The first example is a static waveform from Figure 27. The voltages  $V1$  and  $V0$  will be assigned values of 1 and 0, respectively. The next step is to construct a matrix for one frame to help visualize the DC and RMS

voltages present on an individual pixel when it is ON and when it is OFF. Example 1 shows the calculation of the DC, RMS, and discrimination ratio.

## EXAMPLE 1: DISCRIMINATION RATIO CALCULATION FOR STATIC MUX

COMx 0 1  
 SEGx 1 0 ON  
       0 1 OFF

$$\begin{aligned} \text{COMx} - \text{SEGx} [\text{ON}] &= -1 + 1, & V_{\text{DC}} &= 0 \\ \text{COMx} - \text{SEGx} [\text{OFF}] &= 0 + 0, & V_{\text{DC}} &= 0 \end{aligned}$$

$$V_{\text{RMS}}[\text{ON}] = \Delta V \sqrt{\frac{(-1)^2 + (1)^2}{2}} = 1\Delta V$$

$$V_{\text{RMS}}[\text{OFF}] = \Delta V \sqrt{\frac{(0)^2 + (0)^2}{2}} = 0\Delta V$$

$$D = \frac{V_{\text{RMS}}[\text{ON}]}{V_{\text{RMS}}[\text{OFF}]} = \frac{1\Delta V}{0\Delta V} = \infty$$

The next examples are for [Figure 28](#) which is a Type-A, 1/8 MUX, 1/3 Bias waveform, and for [Figure 29](#) which is a Type-B, 1/8 MUX, 1/3 Bias waveform. For these examples, the values 3, 2, 1, and 0 will be assigned to  $V_3$ ,  $V_2$ ,  $V_1$ , and  $V_0$ , respectively. The frame matrix, DC voltage, RMS voltage and discrimination ratio calculations for the two waveforms are shown in [Example 2](#) and [Example 3](#), respectively.

**EXAMPLE 2: DISCRIMINATION RATIO CALCULATION FOR TYPE-A 1/8 MUX, 1/3 BIAS**

COM0	0	3	2	1	2	1	2	1	2	1	2	1	2	1	2	1	2	1	2
COM1	2	1	0	3	2	1	2	1	2	1	2	1	2	1	2	1	2	1	2
COM2	2	1	2	1	0	3	2	1	2	1	2	1	2	1	2	1	2	1	2
COM3	2	1	2	1	2	1	0	3	2	1	2	1	2	1	2	1	2	1	2
COM4	2	1	2	1	2	1	2	1	0	3	2	1	2	1	2	1	2	1	2
COM5	2	1	2	1	2	1	2	1	2	1	0	3	2	1	2	1	2	1	2
COM6	2	1	2	1	2	1	2	1	2	1	2	1	0	3	2	1	2	1	2
COM7	2	1	2	1	2	1	2	1	2	1	2	1	2	1	0	3	2	1	2
SEGx	3	0	3	0	3	0	3	0	3	0	3	0	3	0	3	0	3	0	ON
	1	2	1	2	1	2	1	2	1	2	1	2	1	2	1	2	1	2	OFF

$$\text{COM0} - \text{SEGx [ON]} = -3 + 3 - 1 + 1 - 1 + 1 - 1 + 1 - 1 + 1 - 1 + 1 - 1 + 1 - 1 + 1 - 1 + 1, V_{\text{DC}} = 0$$

$$\text{COM0} - \text{SEGx [OFF]} = -1 + 1 + 1 - 1 + 1 - 1 + 1 - 1 + 1 - 1 + 1 - 1 + 1 - 1 + 1 - 1 + 1 - 1, V_{\text{DC}} = 0$$

$$V_{\text{RMS}}[\text{ON}] = \Delta V \sqrt{\frac{(-3)^2 + (3)^2 + (-1)^2 + (1)^2 + (-1)^2 + (1)^2 + (-1)^2 + (1)^2 + (-1)^2 + (1)^2 + (-1)^2 + (1)^2 + (-1)^2 + (1)^2 + (-1)^2 + (1)^2}{16}}$$

$$V_{\text{RMS}}[\text{ON}] = \sqrt{2}\Delta V$$

$$V_{\text{RMS}}[\text{OFF}] = \Delta V \sqrt{\frac{(-1)^2 + (1)^2 + (1)^2 + (-1)^2 + (1)^2 + (-1)^2 + (1)^2 + (-1)^2 + (1)^2 + (-1)^2 + (1)^2 + (-1)^2 + (1)^2 + (-1)^2 + (1)^2 + (-1)^2}{16}}$$

$$V_{\text{RMS}}[\text{OFF}] = 1\Delta V$$

$$D = \frac{V_{\text{RMS}}[\text{ON}]}{V_{\text{RMS}}[\text{OFF}]} = \frac{\sqrt{2}\Delta V}{1\Delta V} = 1.414$$

**EXAMPLE 3: DISCRIMINATION RATIO CALCULATION FOR TYPE-B 1/8 MUX, 1/3 BIAS**

COM0	0	2	2	2	2	2	2	2	2	3	1	1	1	1	1	1	1	1	
COM1	2	0	2	2	2	2	2	2	2	1	3	1	1	1	1	1	1	1	
COM2	2	2	0	2	2	2	2	2	2	1	1	3	1	1	1	1	1	1	
COM3	2	2	2	0	2	2	2	2	2	1	1	1	3	1	1	1	1	1	
COM4	2	2	2	2	0	2	2	2	2	1	1	1	1	3	1	1	1	1	
COM5	2	2	2	2	0	2	2	2	2	1	1	1	1	1	3	1	1	1	
COM6	2	2	2	2	2	0	2	2	2	1	1	1	1	1	1	3	1	1	
COM7	2	2	2	2	2	2	0	2	2	1	1	1	1	1	1	1	3	1	
SEGx	3	3	3	3	3	3	3	3	3	0	0	0	0	0	0	0	0	0	ON
	1	1	1	1	1	1	1	1	1	2	2	2	2	2	2	2	2	2	OFF

←----- 2 Frames -----→

$$\text{COM0} - \text{SEGx [ON]} = -3 - 1 - 1 - 1 - 1 - 1 - 1 - 1 - 1 + 3 + 1 + 1 + 1 + 1 + 1 + 1 + 1, \quad V_{\text{DC}} = 0$$

$$\text{COM0} - \text{SEGx [OFF]} = -1 + 1 + 1 + 1 + 1 + 1 + 1 + 1 + 1 - 1 - 1 - 1 - 1 - 1 - 1 - 1 - 1, \quad V_{\text{DC}} = 0$$

$$V_{\text{RMS}}[\text{ON}] = \Delta V \sqrt{\frac{(-3)^2 + (-1)^2 + (-1)^2 + (-1)^2 + (-1)^2 + (-1)^2 + (-1)^2 + (-1)^2 + (3)^2 + (1)^2 + (1)^2 + (1)^2 + (1)^2 + (1)^2 + (1)^2 + (1)^2}{16}}$$

$$V_{\text{RMS}}[\text{ON}] = \sqrt{2}\Delta V$$

$$V_{\text{RMS}}[\text{OFF}] = \Delta V \sqrt{\frac{(-1)^2 + (1)^2 + (1)^2 + (1)^2 + (1)^2 + (1)^2 + (1)^2 + (1)^2 + (1)^2 + (-1)^2 + (-1)^2 + (-1)^2 + (-1)^2 + (-1)^2 + (-1)^2 + (-1)^2}{16}}$$

$$V_{\text{RMS}}[\text{OFF}] = 1\Delta V$$

$$D = \frac{V_{\text{RMS}}[\text{ON}]}{V_{\text{RMS}}[\text{OFF}]} = \frac{\sqrt{2}\Delta V}{1\Delta V} = 1.414$$

Notice that two frames were used for the Type-B waveform since its phase changes on each frame boundary and takes two frames to maintain a 0 VDC. Nevertheless, the two examples resulted into the same value of discrimination ratio.

As shown in these examples, static displays have excellent contrast. The higher the multiplex ratio of the LCD, the lower the discrimination ratio, and therefore, the lower the contrast of the display.

The following table shows the  $V_{OFF}$ ,  $V_{ON}$  and discrimination ratios of the various combinations of MUX and bias.

**TABLE 9: DISCRIMINATION RATIO vs. MUX AND BIAS**

MUX	1/3 Bias		
	$V_{RMS}[OFF]$	$V_{RMS}[ON]$	D
Static	0	1	$\infty$
1/2	0.333	0.745	2.236
1/3	0.333	0.638	1.915
1/4	0.333	0.577	1.732
1/5	0.333	0.537	1.612
1/6	0.333	0.509	1.528
1/7	0.333	0.488	1.464
1/8	0.333	0.471	1.414

Table 9 shows that as the multiplex of the LCD panel increases, the discrimination ratio decreases. The contrast of the panel will also decrease. This relationship is shown graphically in Figure 30. So to provide better contrast, the LCD voltages must be increased to provide greater separation between each level.

**FIGURE 30: DISCRIMINATION RATIO vs. MUX**

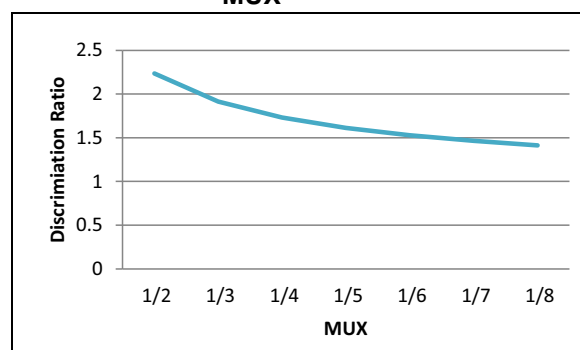

## LCD SEGMENT MAPPING

Segment mapping provides a simple and organized method in determining which pixels should be ON or OFF. The LCD Explorer Demonstration Board with a PIC18F97J94 plug-in module is used in the following example. Figure 31 illustrates the glass layout with the pixel name/numbering, and Table 10 shows the COM and SEG combinations corresponding to a specific pixel in the display.

FIGURE 31: LCD EXPLORER GLASS LAYOUT WITH PIXEL NAME/NUMBERING

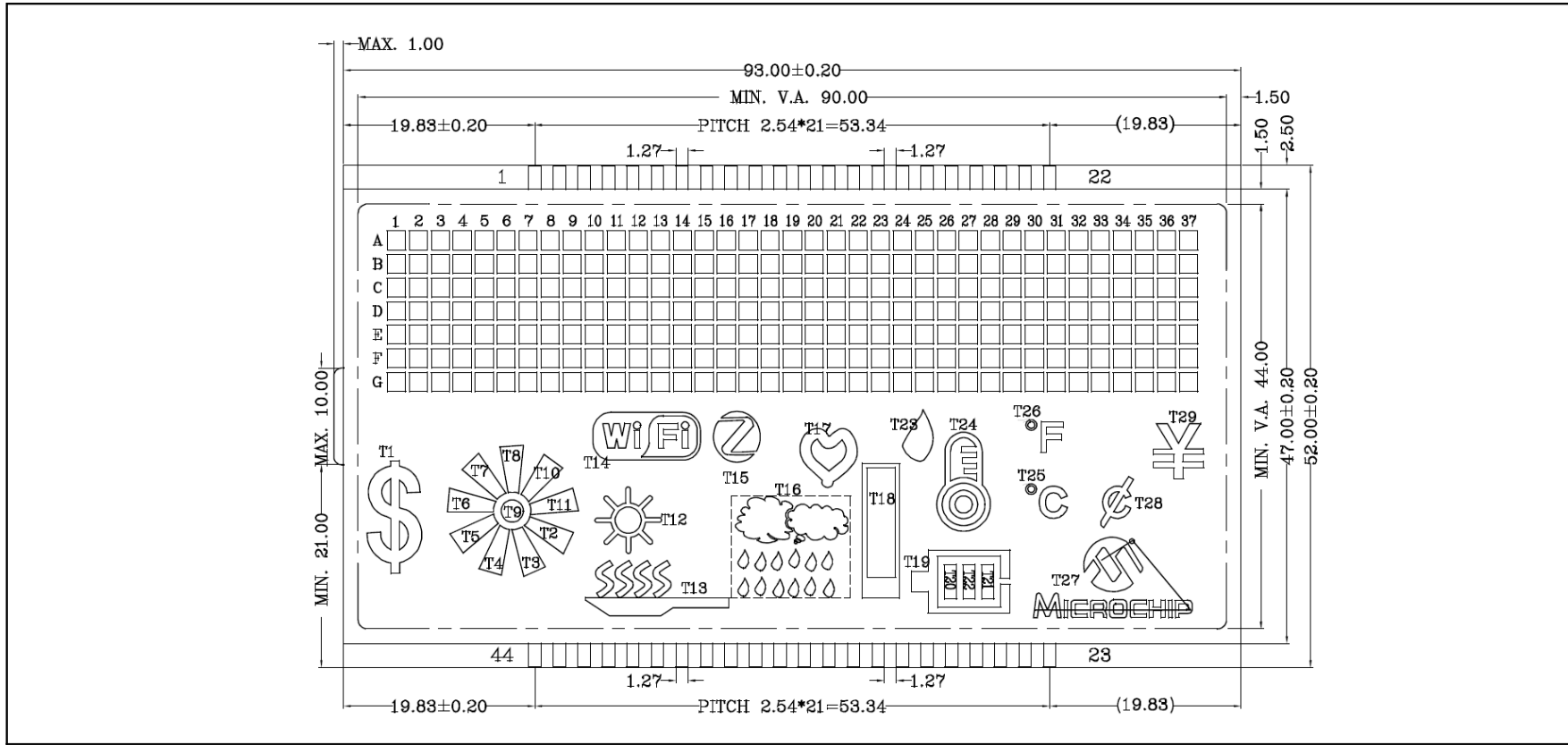

TABLE 10: COM vs. SEGMENT

PIN	1	2	3	4	5	6	7	8	9	10	11	12	13	14	15	16	17	18	19	20	21	22	23	24	25	26	27	28	29	30	31	32	33	34	35	36	37	38	39	40	41	42	43	44
COM1	1A	2A	3A	4A	5A	6A	7A	8A	9A	10A	11A	12A	20A	21A	22A	30A	31A	32A	33A	34A	35A	36A	29A	28A	27A	26A	25A	24A	23A	19A	18A	17A	16A	15A	14A	13A	\\	\\	\\	\\	\\	\\	\\	COM1
COM2	1B	2B	3B	4B	5B	6B	7B	8B	9B	10B	11B	12B	20B	21B	22B	30B	31B	32B	33B	34B	35B	36B	29B	28B	27B	26B	25B	24B	23B	19B	18B	17B	16B	15B	14B	13B	\\	\\	\\	\\	\\	\\	\\	COM2
COM3	1C	2C	3C	4C	5C	6C	7C	8C	9C	10C	11C	12C	20C	21C	22C	30C	31C	32C	33C	34C	35C	36C	29C	28C	27C	26C	25C	24C	23C	19C	18C	17C	16C	15C	14C	13C	\\	\\	\\	\\	\\	\\	\\	COM3
COM4	1D	2D	3D	4D	5D	6D	7D	8D	9D	10D	11D	12D	20D	21D	22D	30D	31D	32D	33D	34D	35D	36D	29D	28D	27D	26D	25D	24D	23D	19D	18D	17D	16D	15D	14D	13D	\\	\\	\\	\\	\\	\\	\\	COM4
COM5	1E	2E	3E	4E	5E	6E	7E	8E	9E	10E	11E	12E	20E	21E	22E	30E	31E	32E	33E	34E	35E	36E	29E	28E	27E	26E	25E	24E	23E	19E	18E	17E	16E	15E	14E	13E	\\	\\	\\	\\	\\	\\	\\	COM5
COM6	1F	2F	3F	4F	5F	6F	7F	8F	9F	10F	11F	12F	20F	21F	22F	30F	31F	32F	33F	34F	35F	36F	29F	28F	27F	26F	25F	24F	23F	19F	18F	17F	16F	15F	14F	13F	\\	\\	\\	\\	\\	\\	\\	COM6
COM7	1G	2G	3G	4G	5G	6G	7G	8G	9G	10G	11G	12G	20G	21G	22G	30G	31G	32G	33G	34G	35G	36G	29G	28G	27G	26G	25G	24G	23G	19G	18G	17G	16G	15G	14G	13G	\\	\\	\\	\\	\\	\\	\\	COM7
COM8	T1	T2	T3	T4	T5	T6	T7	T8	T9	T10	T11	T12	T20	T21	T22	37A	37B	37C	37D	37E	37F	37G	T29	T28	T27	T26	T25	T24	T23	T19	T18	T17	T16	T15	T14	T13	COM8	\\	\\	\\	\\	\\	\\	\\

TABLE 11: SEGMENT MAPPING FOR PIC18F97J94

LCD Function	COM0		COM1		COM2		COM3		COM4		COM5		COM6		COM7	
	LCDDATAx Address, Bit	LCD Segment	LCDDATAx Address	LCD Segment	LCDDATAx Address	LCD Segment	LCDDATAx Address	LCD Segment	LCDDATAx Address	LCD Segment	LCDDATAx Address	LCD Segment	LCDDATAx Address	LCD Segment	LCDDATAx Address	LCD Segment
SEG0	LCDDATA0, 0	32A	LCDDATA8, 0	32B	LCDDATA16, 0	32C	LCDDATA24, 0	32D	LCDDATA32, 0	32E	LCDDATA40, 0	32F	LCDDATA48, 0	32G	LCDDATA56, 0	37C
SEG1	LCDDATA0, 1	31A	LCDDATA8, 1	31B	LCDDATA16, 1	31C	LCDDATA24, 1	31D	LCDDATA32, 1	31E	LCDDATA40, 1	31F	LCDDATA48, 1	31G	LCDDATA56, 1	37B
SEG2	LCDDATA0, 2	14A	LCDDATA8, 2	14B	LCDDATA16, 2	14C	LCDDATA24, 2	14D	LCDDATA32, 2	14E	LCDDATA40, 2	14F	LCDDATA48, 2	14G	LCDDATA56, 2	T14
SEG3	LCDDATA0, 3	13A	LCDDATA8, 3	13B	LCDDATA16, 3	13C	LCDDATA24, 3	13D	LCDDATA32, 3	13E	LCDDATA40, 3	13F	LCDDATA48, 3	13G	LCDDATA56, 3	T13
SEG4	LCDDATA0, 4	12A	LCDDATA8, 4	12B	LCDDATA16, 4	12C	LCDDATA24, 4	12D	LCDDATA32, 4	12E	LCDDATA40, 4	12F	LCDDATA48, 4	12G	LCDDATA56, 4	T12
SEG5	LCDDATA0, 5	30A	LCDDATA8, 5	30B	LCDDATA16, 5	30C	LCDDATA24, 5	30D	LCDDATA32, 5	30E	LCDDATA40, 5	30F	LCDDATA48, 5	30G	LCDDATA56, 5	37A
SEG6	LCDDATA0, 6	29A	LCDDATA8, 6	29B	LCDDATA16, 6	29C	LCDDATA24, 6	29D	LCDDATA32, 6	29E	LCDDATA40, 6	29F	LCDDATA48, 6	29G	LCDDATA56, 6	T29
SEG7	LCDDATA0, 7	22A	LCDDATA8, 7	22B	LCDDATA16, 7	22C	LCDDATA24, 7	22D	LCDDATA32, 7	22E	LCDDATA40, 7	22F	LCDDATA48, 7	22G	LCDDATA56, 7	T22
SEG8	LCDDATA1, 0	20A	LCDDATA9, 0	20B	LCDDATA17, 0	20C	LCDDATA25, 0	20D	LCDDATA33, 0	20E	LCDDATA41, 0	20F	LCDDATA49, 0	20G	LCDDATA57, 0	T20
SEG9	LCDDATA1, 1		LCDDATA9, 1		LCDDATA17, 1		LCDDATA25, 1		LCDDATA33, 1		LCDDATA41, 1		LCDDATA49, 1		LCDDATA57, 1	
SEG10	LCDDATA1, 2		LCDDATA9, 2		LCDDATA17, 2		LCDDATA25, 2		LCDDATA33, 2		LCDDATA41, 2		LCDDATA49, 2		LCDDATA57, 2	
SEG11	LCDDATA1, 3	21A	LCDDATA9, 3	21B	LCDDATA17, 3	21C	LCDDATA25, 3	21D	LCDDATA33, 3	21E	LCDDATA41, 3	21F	LCDDATA49, 3	21G	LCDDATA57, 3	T21
SEG12	LCDDATA1, 4		LCDDATA9, 4		LCDDATA17, 4		LCDDATA25, 4		LCDDATA33, 4		LCDDATA41, 4		LCDDATA49, 4		LCDDATA57, 4	
SEG13	LCDDATA1, 5		LCDDATA9, 5		LCDDATA17, 5		LCDDATA25, 5		LCDDATA33, 5		LCDDATA41, 5		LCDDATA49, 5		LCDDATA57, 5	
SEG14	LC DATA1, 6		LCDDATA9, 6		LCDDATA17, 6		LCDDATA25, 6		LCDDATA33, 6		LCDDATA41, 6		LCDDATA49, 6		LCDDATA57, 6	
SEG15	LCDDATA1, 7		LCDDATA9, 7		LCDDATA17, 7		LCDDATA25, 7		LCDDATA33, 7		LCDDATA41, 7		LCDDATA49, 7		LCDDATA57, 7	
SEG16	LCDDATA2, 0		LCDDATA10, 0		LCDDATA18, 0		LCDDATA26, 0		LCDDATA34, 0		LCDDATA42, 0		LCDDATA50, 0		LCDDATA58, 0	
SEG17	LCDDATA2, 1		LCDDATA10, 1		LCDDATA18, 1		LCDDATA26, 1		LCDDATA34, 1		LCDDATA42, 1		LCDDATA50, 1		LCDDATA58, 1	
SEG18	LCDDATA2, 2		LCDDATA10, 2		LCDDATA18, 2		LCDDATA26, 2		LCDDATA34, 2		LCDDATA42, 2		LCDDATA50, 2		LCDDATA58, 2	
SEG19	LCDDATA2, 3	27A	LCDDATA10, 3	27B	LCDDATA18, 3	27C	LCDDATA26, 3	27D	LCDDATA34, 3	27E	LCDDATA42, 3	27F	LCDDATA50, 3	27G	LCDDATA58, 3	T27
SEG20	LCDDATA2, 4		LCDDATA10, 4		LCDDATA18, 4		LCDDATA26, 4		LCDDATA34, 4		LCDDATA42, 4		LCDDATA50, 4		LCDDATA58, 4	
SEG21	LCDDATA2, 5		LCDDATA10, 5		LCDDATA18, 5		LCDDATA26, 5		LCDDATA34, 5		LCDDATA42, 5		LCDDATA50, 5		LCDDATA58, 5	
SEG22	LCDDATA2, 6	4A	LCDDATA10, 6	4B	LCDDATA18, 6	4C	LCDDATA26, 6	4D	LCDDATA34, 6	4E	LCDDATA42, 6	4F	LCDDATA50, 6	4G	LCDDATA58, 6	T4
SEG23	LCDDATA2, 7		LCDDATA10, 7		LCDDATA18, 7		LCDDATA26, 7		LCDDATA34, 7		LCDDATA42, 7		LCDDATA50, 7		LCDDATA58, 7	
SEG24	LCDDATA3, 0		LCDDATA11, 0		LCDDATA19, 0		LCDDATA27, 0		LCDDATA35, 0		LCDDATA43, 0		LCDDATA51, 0		LCDDATA59, 0	

**TABLE 11: SEGMENT MAPPING FOR PIC18F97J94**

SEG25	LCDDATA3, 1		LCDDATA11, 1		LCDDATA19, 1		LCDDATA27, 1		LCDDATA35, 1		LCDDATA43, 1		LCDDATA51, 1		LCDDATA59, 1	
SEG26	LCDDATA3, 2		LCDDATA11, 2		LCDDATA19, 2		LCDDATA27, 2		LCDDATA35, 2		LCDDATA43, 2		LCDDATA51, 2		LCDDATA59, 2	
SEG27	LCDDATA3, 3	3A	LCDDATA11, 3	3B	LCDDATA19, 3	3C	LCDDATA27, 3	3D	LCDDATA35, 3	3E	LCDDATA43, 3	3F	LCDDATA51, 3	3G	LCDDATA59, 3	T3
SEG28	LCDDATA3, 4		LCDDATA11, 4		LCDDATA19, 4		LCDDATA27, 4		LCDDATA35, 4		LCDDATA43, 4		LCDDATA51, 4		LCDDATA59, 4	
SEG29	LCDDATA3, 5		LCDDATA11, 5		LCDDATA19, 5		LCDDATA27, 5		LCDDATA35, 5		LCDDATA43, 5		LCDDATA51, 5		LCDDATA59, 5	
SEG30	LCDDATA3, 6		LCDDATA11, 6		LCDDATA19, 6		LCDDATA27, 6		LCDDATA35, 6		LCDDATA43, 6		LCDDATA51, 6		LCDDATA59, 6	
SEG31	LCDDATA3, 7		LCDDATA11, 7		LCDDATA19, 7		LCDDATA27, 7		LCDDATA35, 7		LCDDATA43, 7		LCDDATA51, 7		LCDDATA59, 7	
SEG32	LCDDATA4, 0	11A	LCDDATA12, 0	11B	LCDDATA20, 0	11C	LCDDATA28, 0	11D	LCDDATA36, 0	11E	LCDDATA44, 0	11F	LCDDATA52, 0	11G	LCDDATA60, 0	T11
SEG33	LCDDATA4, 1	10A	LCDDATA12, 1	10B	LCDDATA20, 1	10C	LCDDATA28, 1	10D	LCDDATA36, 1	10E	LCDDATA44, 1	10F	LCDDATA52, 1	10G	LCDDATA60, 1	T10
SEG34	LCDDATA4, 2	9A	LCDDATA12, 2	9B	LCDDATA20, 2	9C	LCDDATA28, 2	9D	LCDDATA36, 2	9E	LCDDATA44, 2	9F	LCDDATA52, 2	9G	LCDDATA60, 2	T9
SEG35	LCDDATA4, 3	7A	LCDDATA12, 3	7B	LCDDATA20, 3	7C	LCDDATA28, 3	7D	LCDDATA36, 3	7E	LCDDATA44, 3	7F	LCDDATA52, 3	7G	LCDDATA60, 3	T7
SEG36	LCDDATA4, 4		LCDDATA12, 4		LCDDATA20, 4		LCDDATA28, 4		LCDDATA36, 4		LCDDATA44, 4		LCDDATA52, 4		LCDDATA60, 4	
SEG37	LCDDATA4, 5	2A	LCDDATA12, 5	2B	LCDDATA20, 5	2C	LCDDATA28, 5	2D	LCDDATA36, 5	2E	LCDDATA44, 5	2F	LCDDATA52, 5	2G	LCDDATA60, 5	T2
SEG38	LCDDATA4, 6	1A	LCDDATA12, 6	1B	LCDDATA20, 6	1C	LCDDATA28, 6	1D	LCDDATA36, 6	1E	LCDDATA44, 6	1F	LCDDATA52, 6	1G	LCDDATA60, 6	T1
SEG39	LCDDATA4, 7	8A	LCDDATA12, 7	8B	LCDDATA20, 7	8C	LCDDATA28, 7	8D	LCDDATA36, 7	8E	LCDDATA44, 7	8F	LCDDATA52, 7	8G	LCDDATA60, 7	T8
SEG40	LCDDATA5, 0	19A	LCDDATA13, 0	19B	LCDDATA21, 0	19C	LCDDATA29, 0	19D	LCDDATA37, 0	19E	LCDDATA45, 0	19F	LCDDATA53, 0	19G	LCDDATA61, 0	T19
SEG41	LCDDATA5, 1	18A	LCDDATA13, 1	18B	LCDDATA21, 1	18C	LCDDATA29, 1	18D	LCDDATA37, 1	18E	LCDDATA45, 1	18F	LCDDATA53, 1	18G	LCDDATA61, 1	T18
SEG42	LCDDATA5, 2		LCDDATA13, 2		LCDDATA21, 2		LCDDATA29, 2		LCDDATA37, 2		LCDDATA45, 2		LCDDATA53, 2		LCDDATA61, 2	
SEG43	LCDDATA5, 3		LCDDATA13, 3		LCDDATA21, 3		LCDDATA29, 3		LCDDATA37, 3		LCDDATA45, 3		LCDDATA53, 3		LCDDATA61, 3	
SEG44	LCDDATA5, 4	25A	LCDDATA13, 4	25B	LCDDATA21, 4	25C	LCDDATA29, 4	25D	LCDDATA37, 4	25E	LCDDATA45, 4	25F	LCDDATA53, 4	25G	LCDDATA61, 4	T25
SEG45	LCDDATA5, 5	36A	LCDDATA13, 5	36B	LCDDATA21, 5	36C	LCDDATA29, 5	36D	LCDDATA37, 5	36E	LCDDATA45, 5	36F	LCDDATA53, 5	36G	LCDDATA61, 5	37G
SEG46	LCDDATA5, 6	35A	LCDDATA13, 6	35B	LCDDATA21, 6	35C	LCDDATA29, 6	35D	LCDDATA37, 6	35E	LCDDATA45, 6	35F	LCDDATA53, 6	35G	LCDDATA61,6	37F
SEG47	LCDDATA5, 7	34A	LCDDATA13, 7	34B	LCDDATA21, 7	34C	LCDDATA29, 7	34D	LCDDATA37, 7	34E	LCDDATA45, 7	34F	LCDDATA53, 7	34G	LCDDATA61, 7	37E
SEG48	LCDDATA6, 0	33A	LCDDATA14, 0	33B	LCDDATA22, 0	33C	LCDDATA30, 0	33D	LCDDATA38, 0	33E	LCDDATA46, 0	33F	LCDDATA54, 0	33G	LCDDATA62, 0	37D
SEG49	LCDDATA6, 1	16A	LCDDATA14, 1	16B	LCDDATA22, 1	16C	LCDDATA30, 1	16D	LCDDATA38, 1	16E	LCDDATA46, 1	16F	LCDDATA54, 1	16G	LCDDATA62, 1	T16
SEG50	LCDDATA6, 2	26A	LCDDATA14, 2	26B	LCDDATA22, 2	26C	LCDDATA30, 2	26D	LCDDATA38, 2	26E	LCDDATA46, 2	26F	LCDDATA54, 2	26G	LCDDATA62, 2	T26
SEG51	LCDDATA6, 3	17A	LCDDATA14, 3	17B	LCDDATA22, 3	17C	LCDDATA30, 3	17D	LCDDATA38, 3	17E	LCDDATA46, 3	17F	LCDDATA54, 3	17G	LCDDATA62, 3	T17
SEG52	LCDDATA6, 4	24A	LCDDATA14, 4	24B	LCDDATA22, 4	24C	LCDDATA30, 4	24D	LCDDATA38, 4	24E	LCDDATA46, 4	24F	LCDDATA54, 4	24G	LCDDATA62, 4	T24
SEG53	LCDDATA6,5		LCDDATA14, 5		LCDDATA22, 5		LCDDATA30, 5		LCDDATA38, 5		LCDDATA46, 5		LCDDATA54, 5		LCDDATA62, 5	
SEG54	LCDDATA6,6		LCDDATA14, 6		LCDDATA22, 6		LCDDATA30, 6		LCDDATA38, 6		LCDDATA46, 6		LCDDATA54, 6		LCDDATA62, 6	



**TABLE 11: SEGMENT MAPPING FOR PIC18F97J94**

SEG55	LCDDATA6,7	28A	LCDDATA14, 7	28B	LCDDATA22,7	28C	LCDDATA30, 7	28D	LCDDATA38, 7	28E	LCDDATA46, 7	28F	LCDDATA54, 7	28G	LCDDATA62, 7	T28
SEG56	LCDDATA7, 0		LCDDATA15, 0		LCDDATA23,0		LCDDATA31, 0		LCDDATA39, 0		LCDDATA47, 0		LCDDATA55, 0		LCDDATA63, 0	
SEG57	LCDDATA7, 1		LCDDATA15, 1		LCDDATA23,1		LCDDATA31, 1		LCDDATA39, 1		LCDDATA47, 1		LCDDATA55, 1		LCDDATA63, 1	
SEG58	LCDDATA7, 2		LCDDATA15, 2		LCDDATA23,2		LCDDATA31, 2		LCDDATA39, 2		LCDDATA47, 2		LCDDATA55, 2		LCDDATA63, 2	
SEG59	LCDDATA7, 3		LCDDATA15, 3		LCDDATA23,3		LCDDATA31, 3		LCDDATA39, 3		LCDDATA47, 3		LCDDATA55, 3		LCDDATA63, 3	
SEG60	LCDDATA7, 4	5A	LCDDATA15, 4	5B	LCDDATA23,4	5C	LCDDATA31, 4	5D	LCDDATA39, 4	5E	LCDDATA47, 4	5F	LCDDATA55, 4	5G	LCDDATA63, 4	T5
SEG61	LCDDATA7, 5	6A	LCDDATA15, 5	6B	LCDDATA23,5	6C	LCDDATA31, 5	6D	LCDDATA39, 5	6E	LCDDATA47, 5	6F	LCDDATA55, 5	6G	LCDDATA63, 5	T6
SEG62	LCDDATA7, 6	23A	LCDDATA15, 6	23B	LCDDATA23,6	23C	LCDDATA31, 6	23D	LCDDATA39, 6	23E	LCDDATA47, 6	23F	LCDDATA55, 6	23G	LCDDATA63, 6	T23
SEG63	LCDDATA7, 7	15A	LCDDATA15, 7	15B	LCDDATA23,7	15C	LCDDATA31, 7	15D	LCDDATA39, 7	15E	LCDDATA47, 7	15F	LCDDATA55, 7	15G	LCDDATA63, 7	T15

- Legend:**
1. Cells in gray color represent unused segments.
  2. Cells in red cannot be implemented for 8-common multiplexing due to COM and SEG shared pins.

The LCD Explorer glass requires only 288 unique COM and SEG combinations to drive all the pixels and function indicators. Since PIC18F97J94 is capable of driving up to 480 segments, it should be expected that there will be 192 unused LCD segments for this application, as shown in [Table 11](#). The table makes it apparent that individual pixels are assigned to a specific LCDDATA bit. Unused SEG pins, can be configured as digital I/O ports by clearing their respective LCDSEx bits. For example, SEG<10:9>, can be configured as digital I/O ports by clearing SE<10:9> (LCDSE1<2:1>) bits.

Since the glass is a 1/8 multiplex type, the LCD module is also configured for 8-commons (LMUX<2:0>=111). This configuration limits the glass from driving several

segments due to the sharing of some COM and SEG pins. These segments are highlighted in red in [Table 11](#). The computation of maximum number of pixels is discussed on the next section.

## NUMBERS OF PIXELS

The maximum number of pixels that can be driven by any PIC microcontroller depends upon the available number of commons and segments. There are instances that a common shares the same pin with a segment which reduces the number of pixels that can be driven by the device. [Equation 2](#) provides the formula for computing the maximum number of pixels for this scenario.

### EQUATION 2: MAXIMUM NUMBER OF PIXELS FOR N COMMONS WITH COM AND SEG SHARED PINS

$$\text{Max No. of Pixels} = (\text{No. of Commons} \times \text{No. of Segments}) - (\text{No. of Commons} \times \text{No. of Shared Pins})$$

### EXAMPLE 4: MAXIMUM NUMBER OF PIXELS CALCULATION FOR PIC18F97J94 USING 6 COMMONS

No. of Segments = 64  
 No. of Commons Used = 6  
 No. of Shared Pin Used = 2\*  
 Max No. of Pixels = (No. of Commons x No. of Segments) – (No. of Commons x No. of Shared Pins)  
 Max No. of Pixels = (6 x 64) – (6 x 2)  
 Max No. of Pixels = 372  
 \*COM4 and COM5 share the same pins with SEG28 and SEG29, respectively.

[Example 4](#) shows that 372 pixels can be driven using 6-common multiplexing for the PIC18F97J94. The device has a maximum of eight commons which means that it is capable of driving a total of 480 pixels.

[Equation 2](#) can be simplified to compute for the maximum number of pixels with no shared pins. The *No. of Shared Pins* simply becomes zero, and [Equation 3](#) can be obtained.

### EQUATION 3: MAXIMUM NUMBER OF PIXELS FOR N COMMONS WITH NO COM AND SEG SHARED PINS

$$\text{Max No. of Pixels} = \text{No. of Commons} \times \text{No. of Segments}$$

With static drive, only COM0 is used and there are no shared pins. So, the maximum number of pixels is simply the number of segments. To know the number of shared pins, refer to the data sheet of the specific device used. [Table A-1](#) of [Appendix A: “8-Bit MCU with Integrated LCD Controllers”](#) shows the maximum number of pixels for some common 8-bit PIC microcontrollers.

## LCD BIAS TYPES

The 8-bit PIC microcontrollers support three bias types:

- Static Bias (two voltage levels:  $V_{SS}$  and  $V_{DD}$ )
- 1/2 Bias (three voltage levels:  $V_{SS}$ ,  $1/2 V_{DD}$  and  $V_{DD}$ )
- 1/3 Bias (four voltage levels:  $V_{SS}$ ,  $1/3 V_{DD}$ ,  $2/3 V_{DD}$  and  $V_{DD}$ )

## LCD BIASING METHODS

Refer to [Table A-1](#) of [Appendix A: “8-Bit MCU with Integrated LCD Controllers”](#) for the summary of bias methods supported by different PIC MCUs.

## External Resistor Biasing

The resistor ladder method is most commonly used for higher  $V_{DD}$  voltages. This method uses inexpensive resistors to create the multilevel LCD voltages. Regardless of the number of pixels that are energized, the current remains constant.

In PIC microcontrollers, the external resistor ladder should be connected to the VLCD1 pin (LCDBias 1), VLCD2 pin (LCDBias 2), VLCD3 pin (LCDBias 3) and  $V_{SS}$ . The VLCD3 pin is used to set the highest voltage to the LCD glass and can be connected to  $V_{DD}$  or a lower voltage.

[Figure 32](#) shows the proper way to connect the resistor ladder to the Bias pins.

**FIGURE 32: EXTERNAL RESISTOR LADDER**

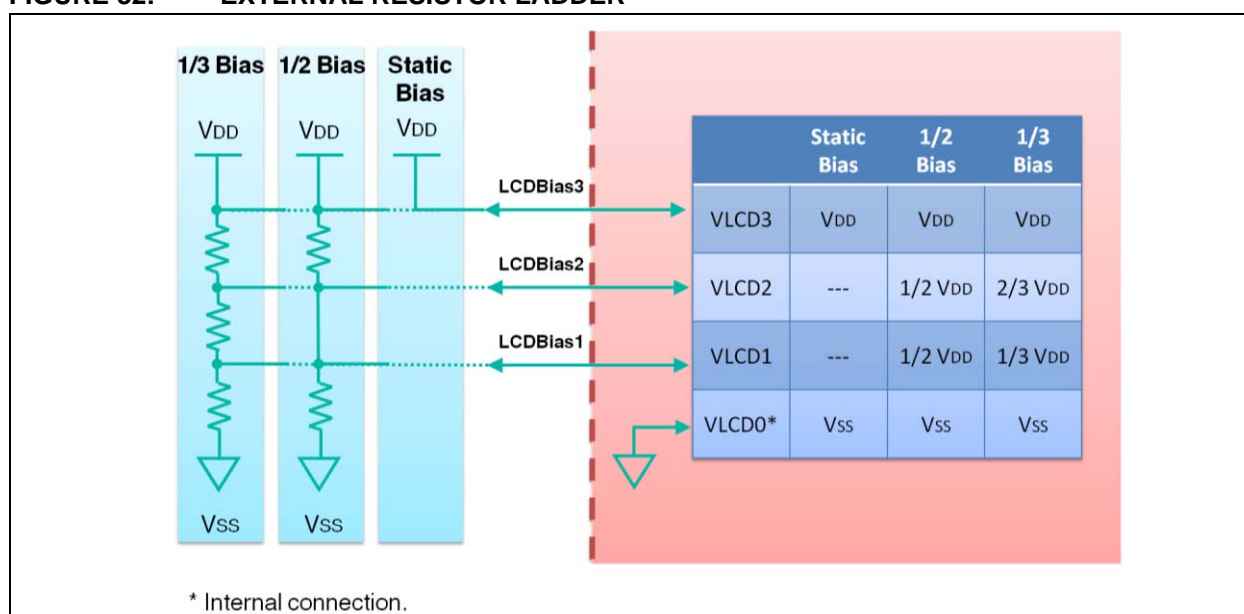

The resistance values are determined by two factors: display quality and power consumption. Display quality is a function of the LCD drive waveforms. Since the LCD panel is a capacitive load, the waveform is distorted due to the charging and discharging currents. This distortion can be reduced by decreasing the value of resistance. However, this change increases the power consumption due to the increased current now flowing through the resistors. As the LCD panel increases in size, the resistance value must be decreased to maintain the image quality of the display.

Sometimes, the addition of capacitors in parallel to the resistance can reduce the distortion caused by charging/discharging currents (see [Figure 33](#)). This effect is limited since at some point, a large resistor and large capacitor cause a voltage level shift which negatively impacts the display quality. The addition of a potentiometer permits external contrast control. In general,  $R$  is  $1\text{ k}\Omega$  to  $50\text{ k}\Omega$  and the potentiometer is  $5\text{ k}\Omega$  to  $200\text{ k}\Omega$ .

FIGURE 33: EXTERNAL RESISTOR LADDER WITH PARALLEL CAPACITORS

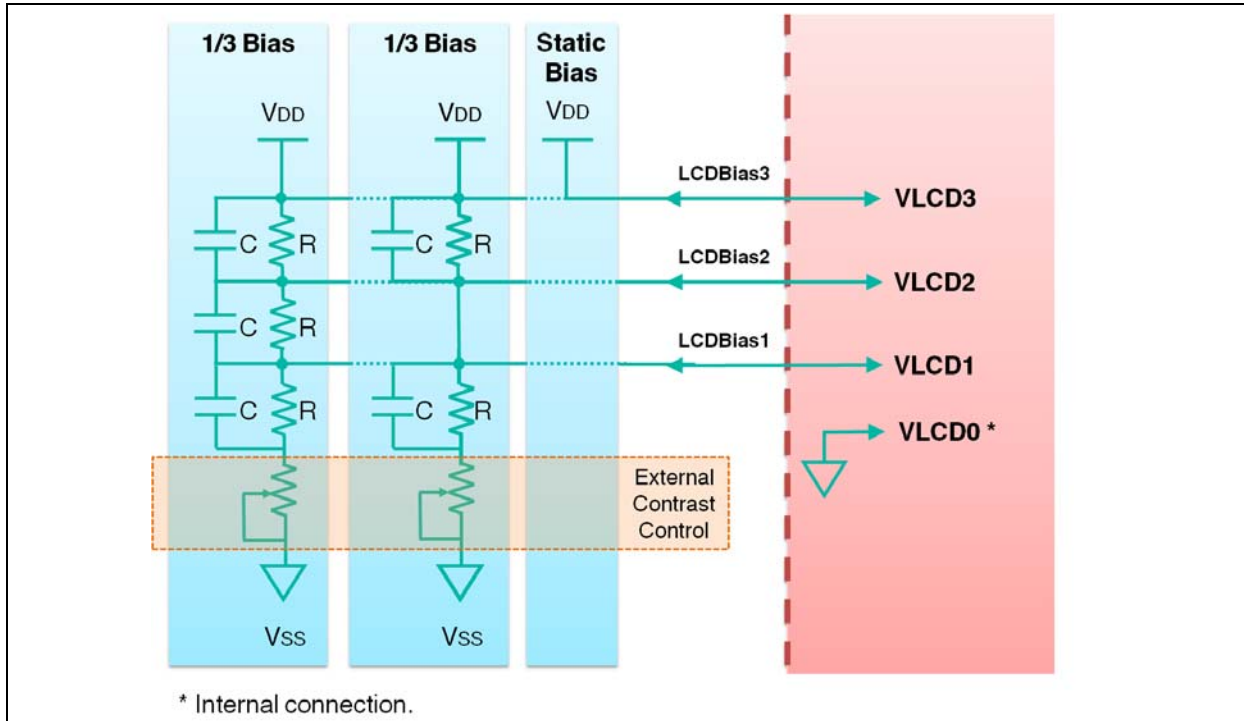

### Internal Resistor Biasing

To avoid the trouble of adding external components and in order for the user to spare the use of up to three pins for voltage generation, PIC microcontrollers provide both internal resistor biasing and internal contrast control. This mode does not use resistors, but rather internal resistor ladders that are configured to generate the bias voltage. These features may be used in conjunction with the external VLCD<3:1> pins, to provide maximum flexibility.

The internal reference ladder can be used to divide the LCD bias voltage to two or three equally spaced voltages that will be supplied to the LCD segment pins. To create this, the reference ladder consists of three matched resistors as shown in [Figure 34](#).

FIGURE 34: INTERNAL RESISTOR LADDER CONNECTION DIAGRAM

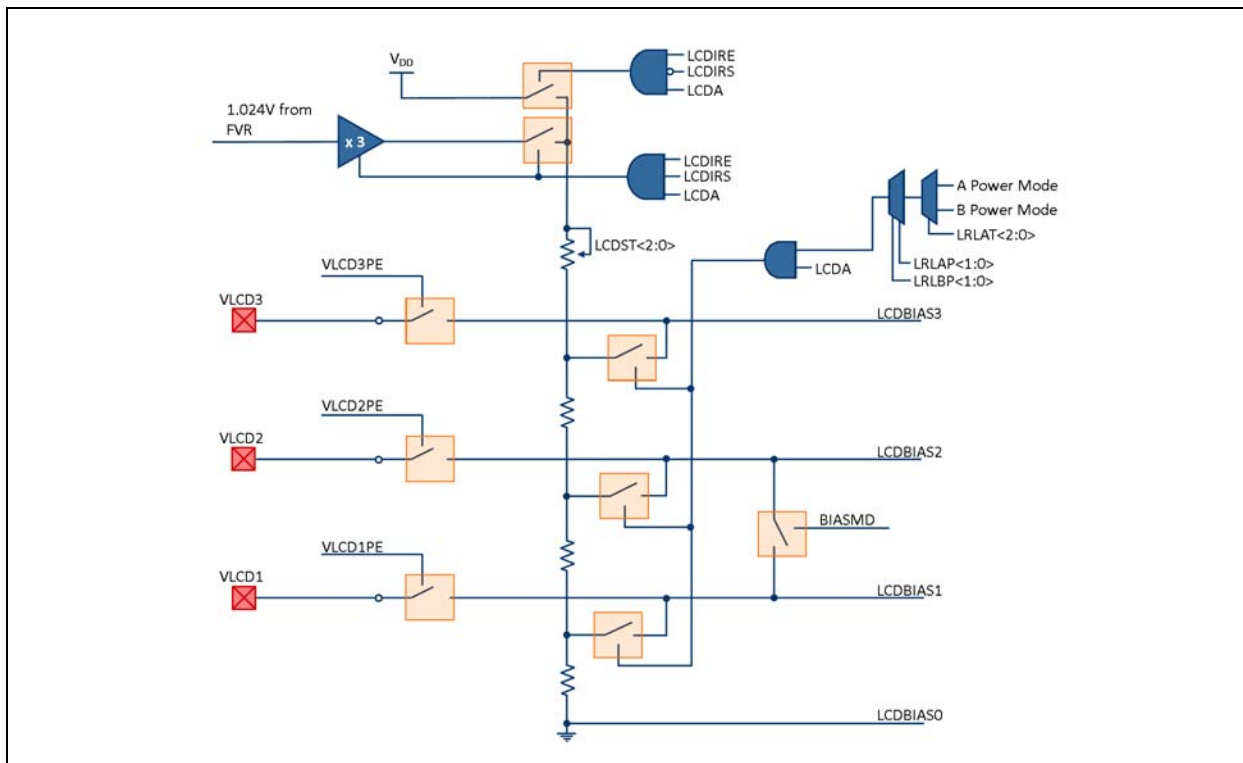

When in 1/2 Bias mode (BIASMD = 1), the middle resistor of the ladder is shorted out so that only two voltages are generated. This mode reduces the ladder resistance, thus increasing current consumption.

Figure 34 is only applicable for the PIC16 devices. For the PIC18 devices, the difference is that the internal reference ladder consists of three separate ladders for the three power modes. The contrast control is also tied to each ladder. All other reference ladder features are more or less the same, including the internal ladder resistance and current values for the different power modes.

Disabling the internal reference ladder disconnects all of the ladders, allowing external voltages to be supplied. This is done by clearing the LCDIRE (LCDREF<7>) bit.

### Power Modes

Depending on the total resistance of the resistor ladders, the biasing can be classified as low, medium or high power. This allows the user to trade off LCD contrast for power in the specific application. The larger the LCD glass, the more capacitance is present on the physical LCD segment, requiring more current to maintain the same contrast level.

Table 12 shows the nominal resistance and nominal I<sub>DD</sub> for each power mode of the ladder. The internal resistor ladder is selected by setting the LCDIRE (LCDREF<7>) bit, which also connects the internal reference to the internal contrast control circuit.

TABLE 12: INTERNAL RESISTANCE LADDER POWER MODES

Power Mode	Nominal Resistance of Entire Ladder	I <sub>DD</sub>
Low	3 MΩ	1 μA
Medium	300 kΩ	10 μA
High	30 kΩ	100 μA

As mentioned earlier, the LCD segment is electrically only a capacitor. So, operating the internal reference ladder in different current modes can reduce the total device current. The LCD module supports automatic power mode switching to optimize the power consumption for a given contrast.

The LCDRL register controls the internal reference ladder power modes.

There are two power modes, designated as “Mode A” and “Mode B”. Mode A is the power mode during Time Interval A and Mode B is the power mode during Time Interval B. They are selected through the LRLAP<1:0> and LRLBP<1:0> bits, respectively. Mode A is active during the time when the LCD segments transition, while Mode B is active for the remaining time before the segments or commons change again.

The LRLAT<2:0> bits select how long the internal reference ladder is in A power mode and B power mode.

There are 32 counts in a single segment time. Mode A can be chosen during the time when the waveform is in transition, whereas Mode B can be used when the clock is stable or not in transition. Figure 35 illustrates

an example of a power mode switching diagram for Type A Waveform in 1/2 MUX, 1/2 Bias with  $LRLAT<2:0> = 011$ .

**FIGURE 35: LCD INTERNAL REFERENCE LADDER POWER MODE SWITCHING DIAGRAM – TYPE A WAVEFORM (1/2 MUX, 1/2 BIAS DRIVE)**

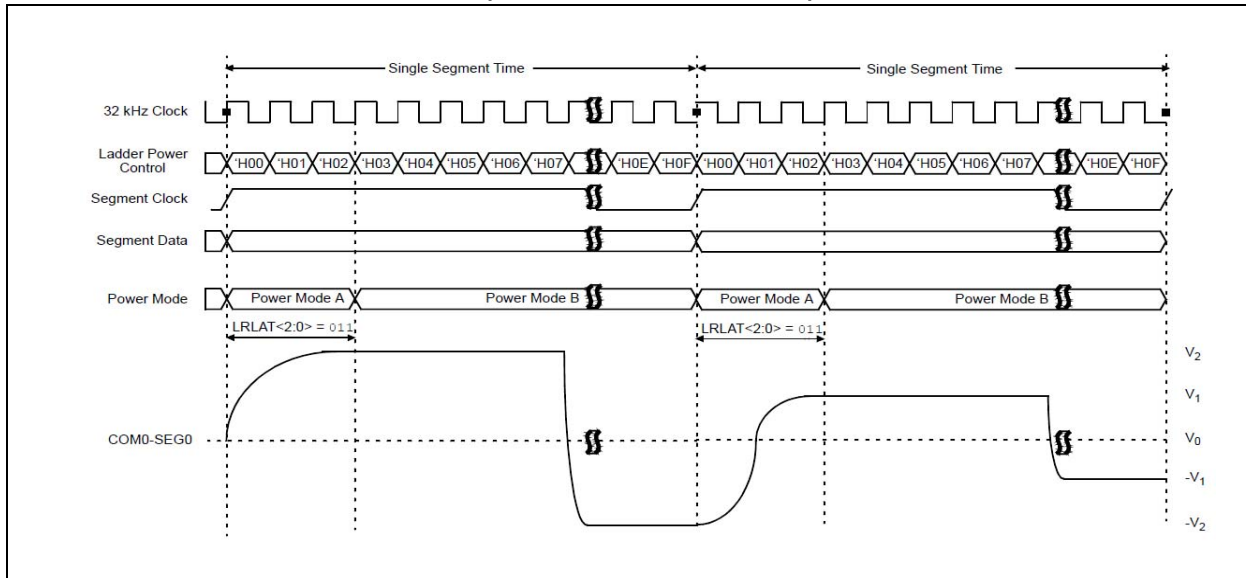

## Internal Reference and Contrast Control

As shown in Figure 36, the internal contrast control circuit consists of a 7-tap resistor ladder, controlled by the LCDCSTx bits.

**FIGURE 36: INTERNAL REFERENCE AND CONTRAST CONTROL**

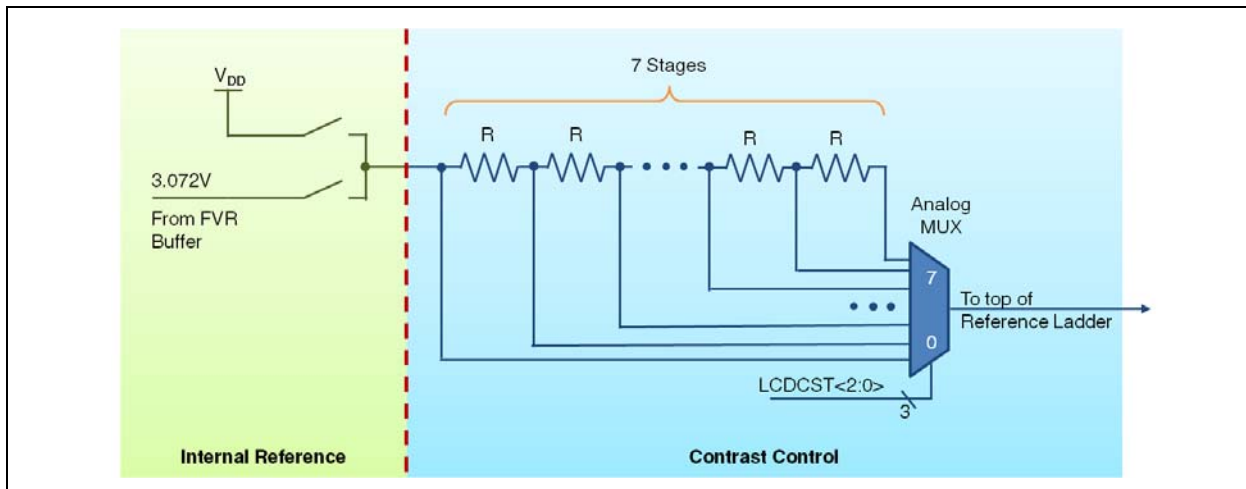

An internal reference for the LCD bias voltages can be enabled through firmware. When enabled, the source of this voltage can be V<sub>DD</sub>. Some devices such as the PIC16F1946/47 and PIC16F193X families have the option between V<sub>DD</sub> and a voltage three times the main Fixed Voltage Reference (3.072 V). When no internal reference is selected, the LCD contrast control circuit is disabled and LCD bias must be provided externally.

## Charge Pump

Another method of generating bias voltages is through a charge pump. A charge pump is ideal for low-voltage battery operation because the VDD voltage can be boosted up to drive the LCD panel. The charge pump requires a charging capacitor and filter capacitor for each of the LCD voltage (VLCDxPE) pin. These capacitors are typically polyester, polypropylene, or polystyrene material. Another feature that makes the charge pump ideal for battery applications is that the current consumption is proportional to the number of pixels that are energized. The LCD charge pump feature is enabled by setting the CPEN bit of the LCDREG register.

## On-Chip LCD Voltage Regulator

PIC18 devices have an on-chip LCD voltage regulator that can provide bias voltages and good contrast for the LCD, regardless of VDD levels. This module contains a charge pump and internal voltage reference. The regulator can be configured by using external components (i.e., capacitors, to boost bias above VDD). It can also operate a display at a constant voltage

below VDD. The regulator can also be selectively disabled to allow bias voltages to be generated by an external resistor network. The LCD regulator is controlled through the LCDREG register.

## Bias Configurations

There are four distinct configurations for the LCD bias generation:

- M0: Regulator with Boost
- M1: Regulator without Boost
- M2: Resistor Ladder with Software Contrast
- M3: Resistor Ladder with Hardware Contrast

Table 13 shows a summary of the different LCD bias configurations.

## Charge Pump Design Considerations

When using the M0 configuration (see Figure 37), the following factors must be considered: the dynamic current and RMS (static) current of the display, and what the charge pump can actually deliver. Both the dynamic and static current can be determined by Equation 4.

### EQUATION 4: STATIC AND DYNAMIC CURRENT EQUATION

$$I = C \times \frac{dV}{dt}$$

For dynamic current,

C = value of the capacitors attached to LCDBIAS3 and LCDBIAS2  
dV = voltage drop allowed on C3 and C2 during voltage switch on the LCD  
dt = duration of the transient current after a clock pulse

For RMS current,

C = C<sub>FLY</sub>  
dV = voltage across V<sub>LCAP1</sub> and V<sub>LCAP2</sub>  
dt = regulator clock period

Example 5 and Example 6 show computations for both the dynamic and RMS current, respectively.

### EXAMPLE 5: DYNAMIC CURRENT COMPUTATION

For practical design purposes,

C = 0.047  $\mu$ F  
dV = 0.1 V  
dt = 1  $\mu$ s

$$I_{DYNAMIC} = 0.047 \mu\text{F} \times \frac{0.1 \text{ V}}{1 \mu\text{s}}$$

$$I_{DYNAMIC} = 4.7 \text{ mA}$$

## EXAMPLE 6: RMS CURRENT COMPUTATION

For practical design purposes,

$$C = 0.047 \mu\text{F}$$
$$dV = 1.02 \text{ V}$$
$$dt = 30 \mu\text{s}$$

$$I_{RMS} = 0.047 \mu\text{F} \times \frac{1.02 \text{ V}}{30 \mu\text{s}}$$
$$I_{RMS} = 1.8 \text{ mA}$$

The maximum theoretical static current is approximately equal to 1.8 mA. Since the charge pump must charge five capacitors, the maximum RMS current becomes 360  $\mu\text{A}$  that will yield a 180  $\mu\text{A}$  for 50% real-world efficiency. Users should always compare the calculated current capacity against the requirements of the LCD. While  $dV$  and  $dt$  are relatively fixed by device design, the values of  $C_{FLY}$  and the capacitors on the LCDBIAS pins can be changed to vary the current. It is always important to take note that changes should be evaluated on the actual circuit for their effect on the application.



**TABLE 13: LCD BIAS CONFIGURATIONS**

Bias Configuration	LCD Regulator	Charge Pump	CPEN	Max Bias Voltage	Bias Voltage Control	Contrast Control	Bias Types	MODE13	Clock Source	CLKSEL<1:0>	Application
M0 (Regulator with Boost)	Enabled	Enabled	1	+3.6 V	BIAS<2:0>	BIAS<2:0>	Static 1/3	0 1	31 kHz LPRC 8 MHz FRC SOSC	11 10 01	Used in cases where the voltage requirements of the LCD are higher than the microcontroller's VDD
M1 (Regulator without Boost)	Enabled	Disabled	0	VDD	BIAS<2:0>	BIAS<2:0>	Static 1/3	0 1	31 kHz LPRC 8 MHz FRC SOSC	11 10 01	Used in cases where VDD is expected to never drop below a level that can provide adequate contrast for the LCD
M2 (External Resistor Ladder with Software Contrast)	Enabled	Disabled	0	VDD	External Resistor Ladder	BIAS<2:0>	1/2 1/3	—	31 kHz LPRC 8 MHz FRC SOSC	11 10 01	Used in cases where the current requirements of the LCD exceed the capacity of the regulator's charge
M3 (Hardware Contrast)	Disabled	Disabled	—	VDD	External Resistor Ladder	External (resistor values VSS and VDD difference, pot adjustment)	Static 1/2 1/3	—	—	—	Used in cases where the LCD's current requirements exceed the capacity of the charge pump and software contrast control is not needed.

**FIGURE 37: LCD BIAS CONFIGURATIONS**

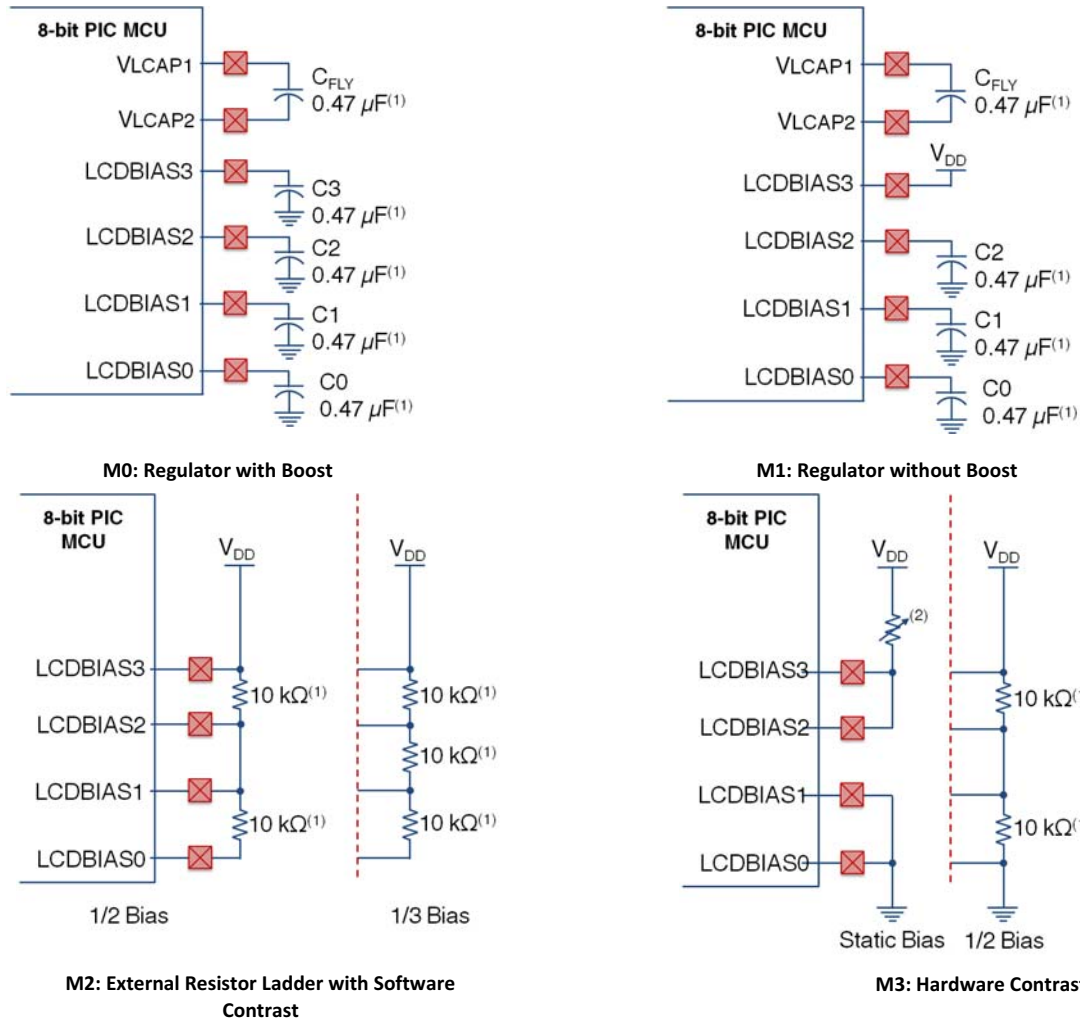

Note 1: These values are provided for design guidance only; they should be optimized for the application by the designer based on the actual LCD specifications.  
 Note 2: A potentiometer for manual contrast adjustment is optional; it may be omitted entirely.

## SAMPLE INITIALIZATION CODE

Included in this application note are two one Hour Countdown Timer application examples. One implements the PIC16F917 with the PICDEM LCD 2 Demo Board, and the other uses the PIC18F97J94 with the LCD Explorer Demo Board.

A sample initialization code for the PIC917 is presented in [Example 7](#). An external resistor ladder incorporated in the PICDEM LCD 2 Demo Board is used for the bias voltage generation and contrast control for this application. The LCD glass will initially display “60:00” until the RB6 button is pressed to start the countdown, and “DONE” will be displayed when the countdown is finished. The firmware flowchart for this application can be found on [Figure E-1](#) of [Appendix E: “Sample Application Firmware”](#).

### EXAMPLE 7: INITIALIZATION CODE FOR THE PIC16F917

```

LCDPS = 0b00000000;           // Type A, Prescaler 1:1, 1/3 Bias Mode
LCDSE0 = 0b01111100;         // SEG2 to SEG6 Enable
LCDSE1 = 0b00000000;         // SEG8 to SEG15 Disable
LCDSE2 = 0b11111000;         // SEG19 to SEG23 Enable
LCDCON = 0b11010111;         // Enable LCD module; LCD disabled in sleep mode
                                // T1OSC Clock Source, 1/4(COM<3:0>) 96 Pixels 1/3 Bias

LCDDATA0 = 0;                 // SEG<7:0>COM0 Pixel off
LCDDATA1 = 0;                 // SEG<15:8>COM0 Pixel off
LCDDATA2 = 0;                 // SEG<23:16>COM0 Pixel off
LCDDATA3 = 0;                 // SEG<7:0>COM1 Pixel off
LCDDATA4 = 0;                 // SEG<15:8>COM1 Pixel off
LCDDATA5 = 0;                 // SEG<23:16>COM1 Pixel off
LCDDATA6 = 0;                 // SEG<7:0>COM2 Pixel off
LCDDATA7 = 0;                 // SEG<15:8>COM2 Pixel off
LCDDATA8 = 0;                 // SEG<23:16>COM2 Pixel off
LCDDATA9 = 0;                 // SEG<7:0>COM3 Pixel off
LCDDATA10 = 0;                // SEG<15:8>COM3 Pixel off
LCDDATA11 = 0;                // SEG<23:16>COM3 Pixel off

```

T1OSC is used as the clock source for this application to achieve exactly one second interval between each count. 1/4 MUX and 1/3 Bias are used as specified in the PICDEM LCD glass specifications. The values of the LCDSE<sub>x</sub> registers can be easily identified by referring to the completed segment mapping table for the PIC16F917 on [Table D-1](#) of [Appendix D: “Segment Mapping”](#). All LCDDATA bits are cleared during the initialization process.

Another initialization code is presented in [Example 6](#). For this application, PIC18F97J94 is configured to use the internal resistor ladder and internal contrast control circuit. The LCD Explorer glass is used to display the one Hour Countdown Timer.

**EXAMPLE 8: INITIALIZATION CODE FOR PIC18F97J94 USING THE INTERNAL REFERENCE LADDER**

```

LCDREF=0xA0; // Enable Internal Reference Ladder; Resistor Ladder 4/7th of max resistance
// BIAS3, BIAS2, BIAS1 levels are internal
LCDRL=0xF7; // Internal Ref Ladder in HP mode during Time Intervals A and B
// Internal Ref Ladder in A Power mode for 7 clocks and B Power mode for 9 clocks
LCDPS=0x02; // Type A waveform; 1/3 Bias mode; 1:3 Prescaler
LCDSE0 = 0xFF; // SEG0 to SEG7 Enabled
LCDSE1 = 0x09; // SEG8 and SEG 10 Enabled
LCDSE2 = 0x48; // SEG19 and SEG22 Enabled
LCDSE3 = 0x08; // SEG27 Enabled
LCDSE4 = 0xEF; // SEG32 to SEG35, SEG37 to SEG39 Enabled
LCDSE5 = 0xF3; // SEG40 to SEG41, SEG44 to SEG47 Enabled
LCDSE6 = 0x9F; // SEG48 to SEG52, SEG55 Enabled
LCDSE7 = 0xF0; // SEG60 to SEG63 Enabled

//Turn off all pixels by clearing the LCDDATAx registers
LCDDATA0 = 0x00; // SEG<7:0>COM0 Pixel off
:
:
LCDDATA63 = 0x00; // SEG<63:56>COM7 Pixel off

LCDCON=0x87; // Enable LCD driver module; disabled in Sleep mode; 1/8 MUX; FRC Clock Source

```

1/8 MUX and 1/3 Bias are used to drive the glass panel. The 8 MHz FRC oscillator divided by 8192 is used to provide the clock for the LCD driver module. For this application, the Secondary Oscillator (SOSC) connected to an external 32.768 kHz crystal is used to clock the Timer1 to provide exact one-second decrement. The LCDSE<sub>x</sub> register values are based on [Table 11](#). The LCDDATA<sub>x</sub> bits are also cleared, except for the LCDDATA58.S19C7 bit to display the Microchip logo at all times.

[Example 9](#) shows a sample initialization code for the M0 configuration using the PIC18F97J94 PIM. The PIC18F97J94 PIM (MA180034) is not designed to use the LCD internal charge pump. If the charge pump feature is really needed for the application, the user has to manually connect, disconnect, and add a few components in the PIM. Take note that when using the PIM

with the LCD Explorer Demo Board for this application, a flyback capacitor must be connected externally to the V<sub>LCAP1</sub> and V<sub>LCAP2</sub> pins of the device, otherwise, the circuit will not work.

Notice that only the values of the LCDREF, LCDRL, and LCDREG registers are different from the previous example. Since the LCD regulator is provided with its own internal voltage reference, the internal reference ladder is disabled for this configuration. The VLCD<3:1> bits are set to '1' to allow filter capacitors to be connected externally. The charge pump enable, contrast control, Biasing mode, and regulator clock source are merely controlled by the LCDREG. Aside from these differences, configuration of the other registers is the same with the one in [Example 8](#).

**EXAMPLE 9: INITIALIZATION CODE FOR PIC18F97J94 USING THE INTERNAL CHARGE PUMP**

```

LCDREG = 0x9E; // Charge Pump enabled; 1/3 LCD Bias mode; SOSC regulator clock source
LCDREF = 0x07; // BIAS<3:1> levels are connected to the external pins, LCDBIAS<3:1>
LCDRL = 0x00; // Internal Reference Ladder unimplemented
LCDPS = 0x02; // Type A waveform; 1/3 Bias mode; 1:3 Prescaler
// LCDSEx and LCDDATAx register values same with Example 8
LCDCON=0x87; // Enable LCD driver module; disabled in Sleep mode; 1/8 MUX; FRC Clock Source

```

## CONCLUSION

Regardless of the type of LCD being implemented on any application and despite the rapid advancements on its technology, the fundamental principles of Liquid Crystal Displays remain unchanged. Everything is based on the polarization of light and the unique behavior of liquid crystals.

This application note employs a progressive approach for the designer not only to learn how an LCD operates and the different factors affecting its performance, but also to provide a brief reference on which devices to use for specific applications.

Microchip offers a wide variety of MCUs with LCD controllers that provide design flexibility and straightforward methods of driving the LCD glass. The internal biasing, contrast control and power-saving features incorporated within the module eliminate the trouble of extra hardware. This application note serves as a guide on how the designer would be able to maximize these features while maintaining the quality of the display.

## APPENDIX A: 8-BIT MCU WITH INTEGRATED LCD CONTROLLERS

### TABLE A-1: 8-BIT MCU LCD MODULE FEATURE COMPARISON

8-bit MCU	Max No. of Commons	Segments	Number of Pixels per Multiplex Type								No. of Clock Source Options	Bias Voltage Generator	Software Contrast Control	LCD Bias		
			Static	1/2	1/3	1/4	1/5	1/6	1/7	1/8				Static	1/2	1/3
PIC18F97J94	8	64	64	128	192	256	315*	372*	427*	480*	3	Internal Resistor Ladder, Charge Pump and Internal Voltage Reference (Internal Boost Regulator)	✓	✓	✓	✓
PIC18F8XJ90	4	48	48	96	144	192	—	—	—	—	3	Charge Pump and Internal Voltage Reference (Internal Boost Regulator)	✓	✓	✓	✓
PIC18F6XJ90	4	33	33	66	99	132	—	—	—	—	3	Charge Pump and Internal Voltage Reference (Internal Boost Regulator)	✓	✓	✓	✓
PIC18F8XK90	4	48	48	96	144	192	—	—	—	—	3	Internal Resistor Ladder	✓	✓	✓	✓
PIC18F6XK90	4	33	33	66	99	132	—	—	—	—	3	Internal Resistor Ladder	✓	✓	✓	✓
PIC18F8X90	4	48	48	96	144	192	—	—	—	—	3	External Resistor Ladder	—	✓	✓	✓
PIC18F6X90	4	32	32	64	96	128	—	—	—	—	3	External Resistor Ladder	—	✓	✓	✓
PIC16(L)F1946/47	4	46	46	92	138	184	—	—	—	—	3	Internal Resistor Ladder	✓	✓	✓	✓
PIC16(L)F1938	4	16	16	32	48	60*	—	—	—	—	3	Internal Resistor Ladder	✓	✓	✓	✓
PIC16(L)F1939	4	24	24	48	72	96	—	—	—	—	3	Internal Resistor Ladder	✓	✓	✓	✓
PIC16LF1906	4	19	19	38	57	72*	—	—	—	—	3	Internal Resistor Ladder	✓	✓	✓	✓
PIC16LF1904/7	4	29	29	58	87	116	—	—	—	—	3	Internal Resistor Ladder	✓	✓	✓	✓
PIC16F913/916	4	16	16	32	48	60*	—	—	—	—	3	External Resistor Ladder	—	✓	✓	✓
PIC16F914/917	4	24	24	48	72	96	—	—	—	—	3	External Resistor Ladder	—	✓	✓	✓
PIC16F946	4	42	42	84	126	168	—	—	—	—	3	External Resistor Ladder	—	✓	✓	✓

\*On these devices, some commons and segments share the same pin.

## APPENDIX B: LCD CLOCK SOURCES

TABLE B-1: 8-BIT MCU FAMILIES LCD CLOCK SOURCE SELECTION

8-Bit MCU Family	Clock Source	Divider Ratio	CS<1:0>	SLPEN	Operation during Sleep?
PIC16F91X	F <sub>OSC</sub> (8 MHz)	8192	00	0	No
				1	No
	T1OSC (32.768 kHz)	32	01	0	Yes
				1	No
	LFINTOSC Nominal = (31 kHz)	32	1x	0	Yes
				1	No
PIC16F190X	F <sub>OSC</sub> /256	32	00	0	No
				1	No
	T1OSC Crystal Oscillator (32.768 kHz)	32	01	0	Yes
				1	No
	LFINTOSC Nominal = 31 kHz	32	1x	0	Yes
				1	No
PIC16F193X	F <sub>OSC</sub> /256	32	00	0	No
				1	No
	T1OSC Crystal Oscillator (32.768 kHz)	32	01	0	Yes
				1	No
	LFINTOSC Nominal = 31 kHz	32	1x	0	Yes
				1	No
PIC16F194X	F <sub>OSC</sub> /256	32	00	0	No
				1	No
	T1OSC Crystal Oscillator (32.768 kHz)	32	01	0	Yes
				1	No
	LFINTOSC Nominal = 31 kHz	32	1x	0	Yes
				1	No
PIC18F8X90	System Clock (F <sub>OSC</sub> /4) = 8 MHz	8192	00	0	No
				1	No
	T13CK1 Crystal Oscillator (32.768 kHz)	32	01	0	Yes
				1	No
	Internal RC Oscillator (31.25 kHz)	32	1x	0	Yes
				1	No
PIC18F8XJ90	(F <sub>OSC</sub> /4) = 8 MHz	8192	00	0	No
				1	No
	Timer1 Oscillator (32 kHz)	32	01	0	Yes
				1	No
	INTRC Source (31 kHz)	32	1x	0	Yes
				1	No
PIC18F8XK90	(F <sub>OSC</sub> /4) = 8 MHz	8192	00	0	No
				1	No
	SOSC Crystal Oscillator (32.768 kHz)	32	01	0	Yes
				1	No
	LF-INTOSC Oscillator (31.25 kHz)	32	1x	0	Yes
				1	No
PIC18F9XJ94	FRC Oscillator (8 MHz)	8192	00	0	No
				1	No
	SOSC Crystal Oscillator (32.768 kHz)	32	01	0	Yes
				1	No
	LPRC Oscillator (31.25 kHz)	32	1x	0	Yes
				1	No

APPENDIX C: PICDEM™ LCD 2 GLASS

FIGURE C-1: DISPLAY DEFINITIONS

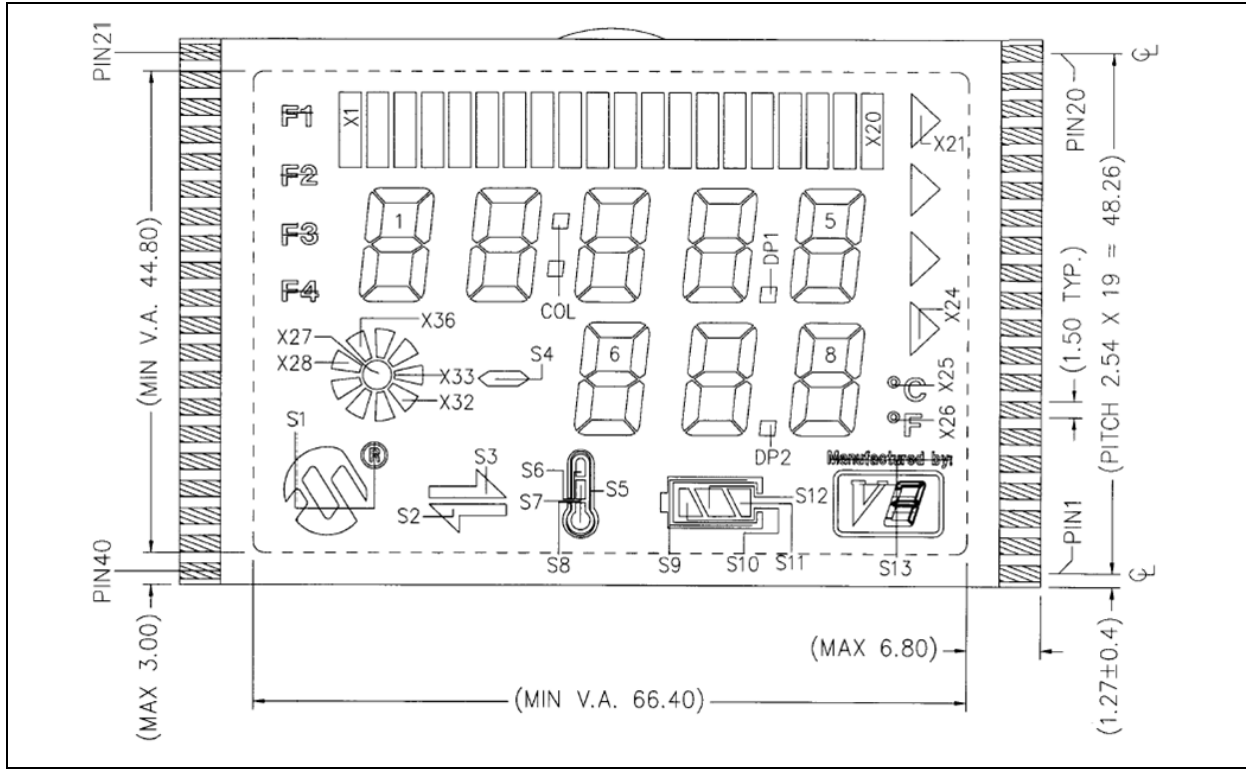
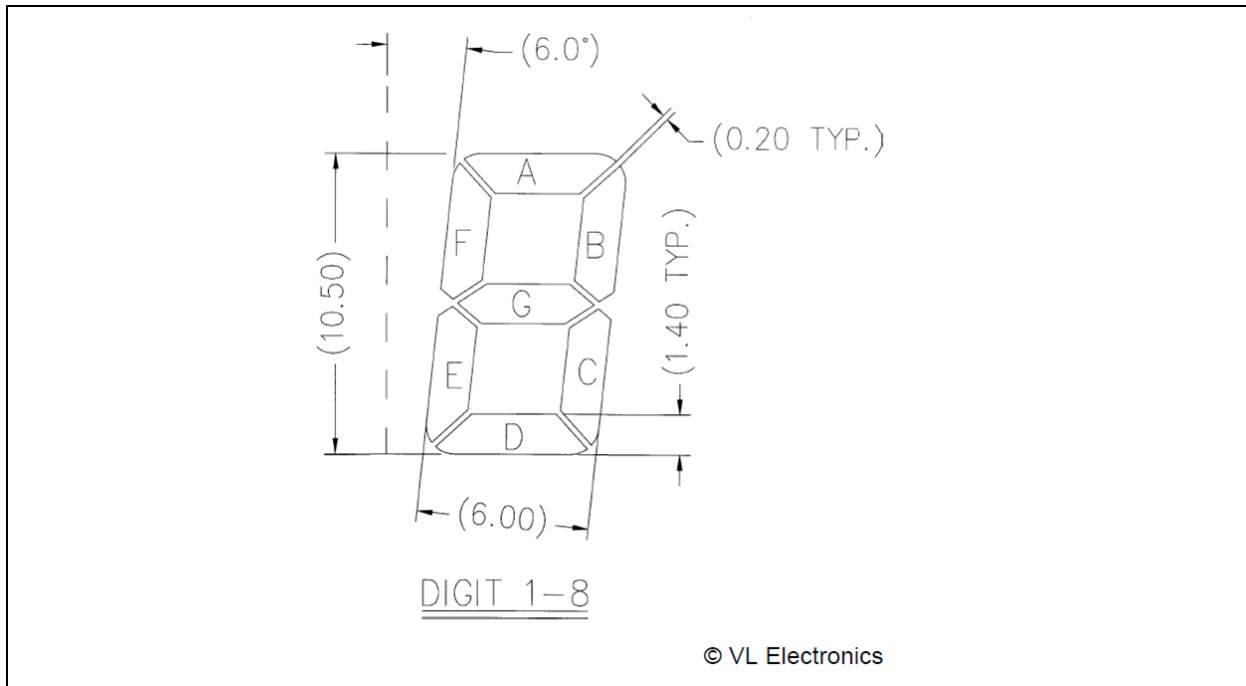

FIGURE C-2: DIGIT DESCRIPTION





## APPENDIX D: SEGMENT MAPPING

TABLE D-1: PIC16F1917 SEGMENT MAPPING

LCD Function	COM0		COM0		COM0		COM0	
	LCDDATx Address, Bit	LCD Segment	LCDDATx Address, Bit	LCD Segment	LCDDATx Address, Bit	LCD Segment	LCDDATx Address, Bit	LCD Segment
SEG0	LCDDATA0, 0		LCDDATA3, 0		LCDDATA6, 0		LCDDATA9,0	
SEG1	LCDDATA0, 1	X23	LCDDATA3, 1	X25	LCDDATA6, 1	X26	LCDDATA9, 1	X24
SEG2	LCDDATA0, 2	5B	LCDDATA3, 2	5C	LCDDATA6, 2		LCDDATA9, 2	5G
SEG3	LCDDATA0, 3	5A	LCDDATA3, 3	5E	LCDDATA6, 3	5D	LCDDATA9, 3	5F
SEG4	LCDDATA0, 4	4B	LCDDATA3, 4	4C	LCDDATA6, 4	DP1	LCDDATA9, 4	4G
SEG5	LCDDATA0, 5	4A	LCDDATA3, 5	4E	LCDDATA6, 5	4D	LCDDATA9, 5	4F
EG6	LCDDATA0, 6	3B	LCDDATA3, 6	3C	LCDDATA6, 6		LCDDATA9, 6	3G
SEG7	LCDDATA0, 7		LCDDATA3, 7		LCDDATA6, 7		LCDDATA9, 7	
SEG8	LCDDATA1, 0		LCDDATA4, 0		LCDDATA7, 0		LCDDATA10, 0	
SEG9	LCDDATA1, 1		LCDDATA4, 1		LCDDATA7, 1		LCDDATA10, 1	
SEG10	LCDDATA1, 2	X17	LCDDATA4, 2	X19	LCDDATA7, 2	X20	LCDDATA10, 2	X18
SEG11	LCDDATA1, 3	X16	LCDDATA4, 3	X14	LCDDATA7, 3	X13	LCDDATA10, 3	X15
SEG12	LCDDATA1, 4		LCDDATA4, 4		LCDDATA7, 4		LCDDATA10, 4	
SEG13	LCDDATA1, 5		LCDDATA4, 5		LCDDATA7, 5		LCDDATA10, 5	
SEG14	LCDDATA1, 6		LCDDATA4, 6		LCDDATA7, 6		LCDDATA10, 6	
SEG15	LCDDATA1, 7	X9	LCDDATA4, 7	X11	LCDDATA7, 7	X12	LCDDATA10, 7	X10
SEG16	LCDDATA2, 0	X8	LCDDATA5, 0	X6	LCDDATA8, 0	X5	LCDDATA11, 0	X7
SEG17	LCDDATA2, 1	X1	LCDDATA5, 1	X3	LCDDATA8, 1	X4	LCDDATA11, 1	X2
SEG18	LCDDATA2, 2		LCDDATA5, 2	F2	LCDDATA8, 2	F1	LCDDATA11, 2	F3
SEG19	LCDDATA2, 3	1A	LCDDATA5, 3	1E	LCDDATA8, 3	F4	LCDDATA11, 3	1F
SEG20	LCDDATA2, 4	1B	LCDDATA5, 4	1C	LCDDATA8, 4	1D	LCDDATA11, 4	1G
SEG21	LCDDATA2, 5	2A	LCDDATA5, 5	2E	LCDDATA8, 5	2D	LCDDATA11, 5	2F
SEG22	LCDDATA2, 6	2B	LCDDATA5, 6	2C	LCDDATA8, 6	COL	LCDDATA11, 6	2G
SEG23	LCDDATA2, 7	3A	LCDDATA5, 7	3E	LCDDATA8, 7	3D	LCDDATA11, 7	3F

**Legend:** Cells in gray represent unused segments; cells in green represent the segments unimplemented in the sample application.

APPENDIX E: SAMPLE APPLICATION FIRMWARE

FIGURE E-1: PIC16F917 DEMO FIRMWARE FLOWCHART

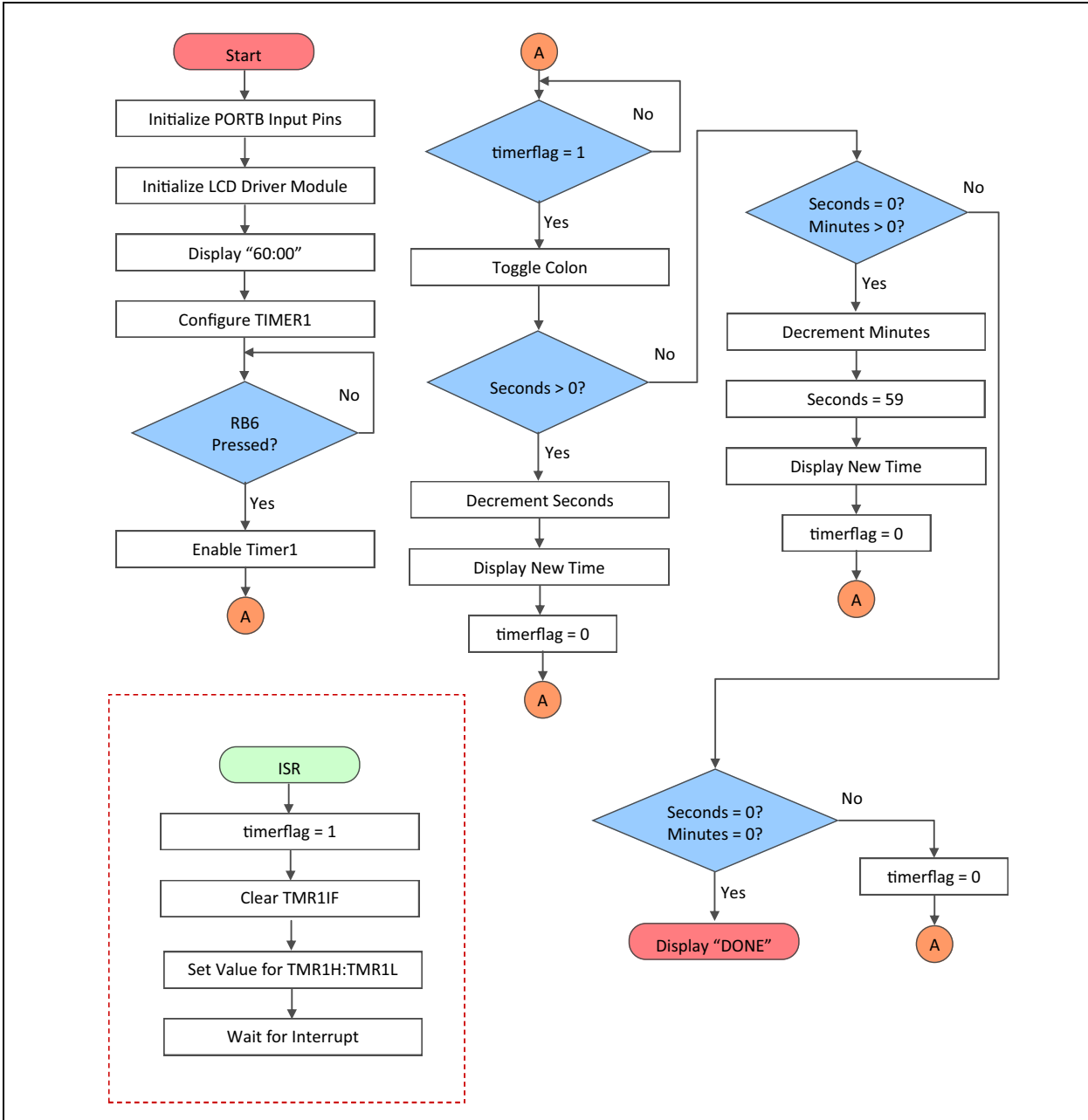
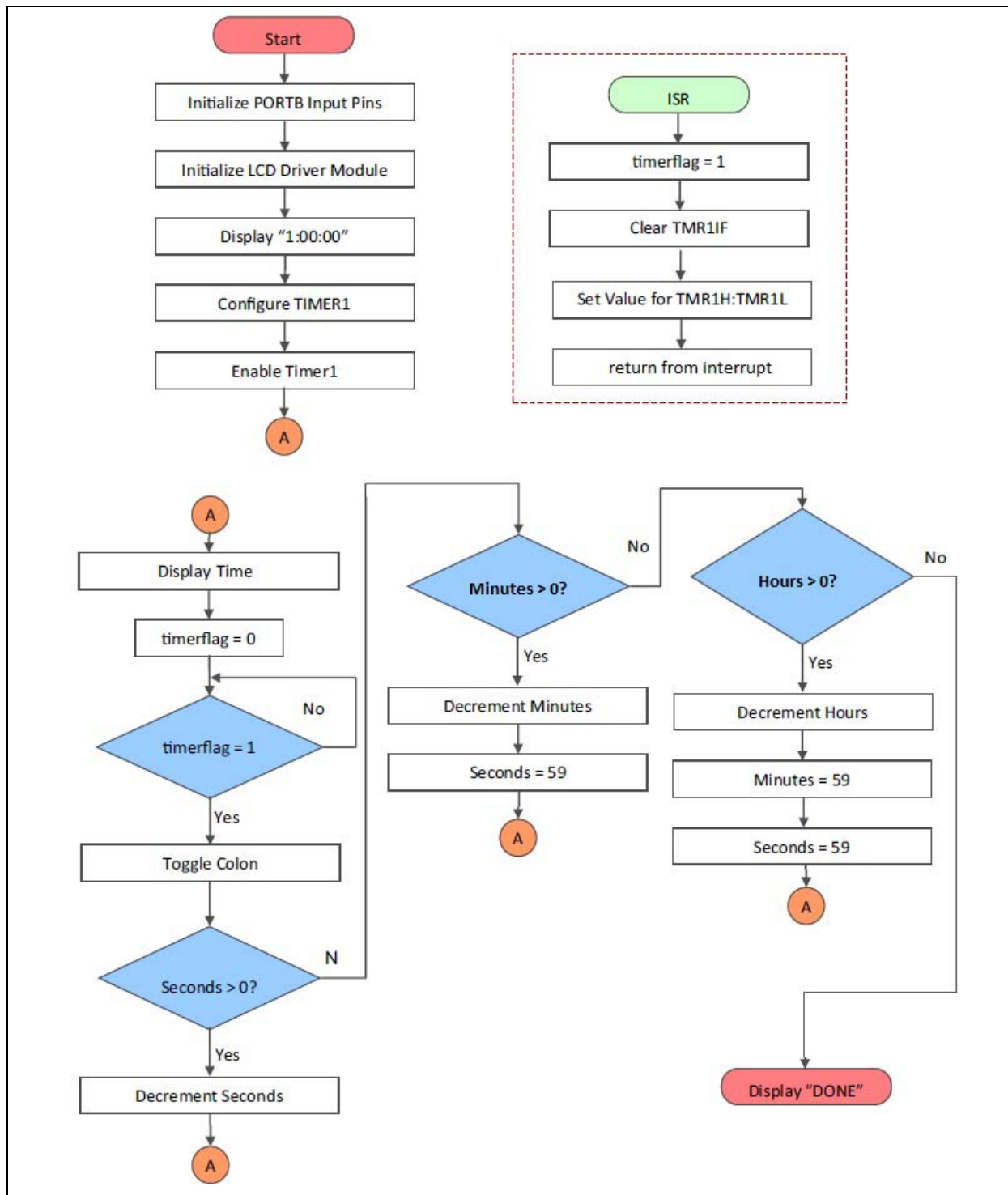

FIGURE E-2: PIC18F97J94 DEMO FIRMWARE FLOWCHART



## APPENDIX F: REFERENCES AND RELATED DOCUMENTS

**TABLE F-1: DATA SHEETS**

PIC18F9XJ94	DS30575	<a href="http://www.microchip.com/wwwproducts/Devices.aspx?product=PIC18F97J94">http://www.microchip.com/wwwproducts/Devices.aspx?product=PIC18F97J94</a>
PIC18F8XK90	DS39957	<a href="http://www.microchip.com/wwwproducts/Devices.aspx?product=PIC18F87K90">http://www.microchip.com/wwwproducts/Devices.aspx?product=PIC18F87K90</a>
PIC18F8XJ90	DS39933	<a href="http://www.microchip.com/wwwproducts/Devices.aspx?product=PIC18F87J90">http://www.microchip.com/wwwproducts/Devices.aspx?product=PIC18F87J90</a>
PIC18F8X90	DS39629	<a href="http://www.microchip.com/wwwproducts/Devices.aspx?product=PIC18F8490">http://www.microchip.com/wwwproducts/Devices.aspx?product=PIC18F8490</a>
PIC16F194X	DS41414	<a href="http://www.microchip.com/wwwproducts/Devices.aspx?product=PIC16F1947">http://www.microchip.com/wwwproducts/Devices.aspx?product=PIC16F1947</a>
PIC16F193X	DS40001574	<a href="http://www.microchip.com/wwwproducts/Devices.aspx?product=PIC16F1939">http://www.microchip.com/wwwproducts/Devices.aspx?product=PIC16F1939</a>
PIC16F190X	DS41569	<a href="http://www.microchip.com/wwwproducts/Devices.aspx?product=PIC16LF1907">http://www.microchip.com/wwwproducts/Devices.aspx?product=PIC16LF1907</a>
PIC16F91X	DS41250	<a href="http://www.microchip.com/wwwproducts/Devices.aspx?product=PIC16F917">http://www.microchip.com/wwwproducts/Devices.aspx?product=PIC16F917</a>

A complete list of PIC MCUs with Integrated LCD Controller can be found on the Microchip web site.

**PIC<sup>®</sup> MCUs with Integrated LCD Controller Product Family:**

<http://www.microchip.com/pagehandler/en-us/technology/lcd/products/integrated-segment-lcd-drivers.html#Jump2Grid>).

**User Guides:**

1. *LCD PICmicro<sup>®</sup> Tips 'n Tricks* (DS41261)
2. *PICDEM LCD 2 User's Guide* (DS51662)
3. *Introducing the LCD Explorer Demonstration Board* (DS52026)
4. *AN1428 – LCD Biasing and Contrast Control Methods* (DS01428)
5. *AN1354 – Implementing an LCD Using the PIC16F1947 Microcontroller* (DS01354)
6. *AN649 – Yet Another Clock Featuring the PIC16C924* (DS00649)
7. *TB1098 – Low-Power Techniques for LCD Applications* (DS91098)
8. *TB084 – Contrast Control Circuits for the PIC16F91X* (DS1084)
9. *PIC18FX7J94 Plug-In Module User's Guide* (DS41687)

---

**Note the following details of the code protection feature on Microchip devices:**

- Microchip products meet the specification contained in their particular Microchip Data Sheet.
- Microchip believes that its family of products is one of the most secure families of its kind on the market today, when used in the intended manner and under normal conditions.
- There are dishonest and possibly illegal methods used to breach the code protection feature. All of these methods, to our knowledge, require using the Microchip products in a manner outside the operating specifications contained in Microchip's Data Sheets. Most likely, the person doing so is engaged in theft of intellectual property.
- Microchip is willing to work with the customer who is concerned about the integrity of their code.
- Neither Microchip nor any other semiconductor manufacturer can guarantee the security of their code. Code protection does not mean that we are guaranteeing the product as “unbreakable.”

Code protection is constantly evolving. We at Microchip are committed to continuously improving the code protection features of our products. Attempts to break Microchip's code protection feature may be a violation of the Digital Millennium Copyright Act. If such acts allow unauthorized access to your software or other copyrighted work, you may have a right to sue for relief under that Act.

---

Information contained in this publication regarding device applications and the like is provided only for your convenience and may be superseded by updates. It is your responsibility to ensure that your application meets with your specifications. MICROCHIP MAKES NO REPRESENTATIONS OR WARRANTIES OF ANY KIND WHETHER EXPRESS OR IMPLIED, WRITTEN OR ORAL, STATUTORY OR OTHERWISE, RELATED TO THE INFORMATION, INCLUDING BUT NOT LIMITED TO ITS CONDITION, QUALITY, PERFORMANCE, MERCHANTABILITY OR FITNESS FOR PURPOSE. Microchip disclaims all liability arising from this information and its use. Use of Microchip devices in life support and/or safety applications is entirely at the buyer's risk, and the buyer agrees to defend, indemnify and hold harmless Microchip from any and all damages, claims, suits, or expenses resulting from such use. No licenses are conveyed, implicitly or otherwise, under any Microchip intellectual property rights.

**Trademarks**

The Microchip name and logo, the Microchip logo, dsPIC, FlashFlex, flexPWR, JukeBlox, KEELOQ, KEELOQ logo, Kleer, LANCheck, MediaLB, MOST, MOST logo, MPLAB, OptoLyzer, PIC, PICSTART, PIC<sup>32</sup> logo, RightTouch, SpyNIC, SST, SST Logo, SuperFlash and UNI/O are registered trademarks of Microchip Technology Incorporated in the U.S.A. and other countries.

The Embedded Control Solutions Company and mTouch are registered trademarks of Microchip Technology Incorporated in the U.S.A.

Analog-for-the-Digital Age, BodyCom, chipKIT, chipKIT logo, CodeGuard, dsPICDEM, dsPICDEM.net, ECAN, In-Circuit Serial Programming, ICSP, Inter-Chip Connectivity, KleerNet, KleerNet logo, MiWi, MPASM, MPF, MPLAB Certified logo, MPLIB, MPLINK, MultiTRAK, NetDetach, Omniscient Code Generation, PICDEM, PICDEM.net, PICkit, PICtail, RightTouch logo, REAL ICE, SQI, Serial Quad I/O, Total Endurance, TSHARC, USBCheck, VariSense, ViewSpan, WiperLock, Wireless DNA, and ZENA are trademarks of Microchip Technology Incorporated in the U.S.A. and other countries.

SQTP is a service mark of Microchip Technology Incorporated in the U.S.A.

Silicon Storage Technology is a registered trademark of Microchip Technology Inc. in other countries.

GestIC is a registered trademarks of Microchip Technology Germany II GmbH & Co. KG, a subsidiary of Microchip Technology Inc., in other countries.

All other trademarks mentioned herein are property of their respective companies.

© 1997-2014, Microchip Technology Incorporated, Printed in the U.S.A., All Rights Reserved.

ISBN: 978-1-63276-796-7

**QUALITY MANAGEMENT SYSTEM**  
**CERTIFIED BY DNV**  
**== ISO/TS 16949 ==**

*Microchip received ISO/TS-16949:2009 certification for its worldwide headquarters, design and wafer fabrication facilities in Chandler and Tempe, Arizona; Gresham, Oregon and design centers in California and India. The Company's quality system processes and procedures are for its PIC<sup>®</sup> MCUs and dsPIC<sup>®</sup> DSCs, KEELOQ<sup>®</sup> code hopping devices, Serial EEPROMs, microperipherals, nonvolatile memory and analog products. In addition, Microchip's quality system for the design and manufacture of development systems is ISO 9001:2000 certified.*



# MICROCHIP

## Worldwide Sales and Service

### AMERICAS

**Corporate Office**  
2355 West Chandler Blvd.  
Chandler, AZ 85224-6199  
Tel: 480-792-7200  
Fax: 480-792-7277  
Technical Support:  
<http://www.microchip.com/support>  
Web Address:  
[www.microchip.com](http://www.microchip.com)

**Atlanta**  
Duluth, GA  
Tel: 678-957-9614  
Fax: 678-957-1455

**Austin, TX**  
Tel: 512-257-3370

**Boston**  
Westborough, MA  
Tel: 774-760-0087  
Fax: 774-760-0088

**Chicago**  
Itasca, IL  
Tel: 630-285-0071  
Fax: 630-285-0075

**Cleveland**  
Independence, OH  
Tel: 216-447-0464  
Fax: 216-447-0643

**Dallas**  
Addison, TX  
Tel: 972-818-7423  
Fax: 972-818-2924

**Detroit**  
Novi, MI  
Tel: 248-848-4000

**Houston, TX**  
Tel: 281-894-5983

**Indianapolis**  
Noblesville, IN  
Tel: 317-773-8323  
Fax: 317-773-5453

**Los Angeles**  
Mission Viejo, CA  
Tel: 949-462-9523  
Fax: 949-462-9608

**New York, NY**  
Tel: 631-435-6000

**San Jose, CA**  
Tel: 408-735-9110

**Canada - Toronto**  
Tel: 905-673-0699  
Fax: 905-673-6509

### ASIA/PACIFIC

**Asia Pacific Office**  
Suites 3707-14, 37th Floor  
Tower 6, The Gateway  
Harbour City, Kowloon  
Hong Kong  
Tel: 852-2943-5100  
Fax: 852-2401-3431

**Australia - Sydney**  
Tel: 61-2-9868-6733  
Fax: 61-2-9868-6755

**China - Beijing**  
Tel: 86-10-8569-7000  
Fax: 86-10-8528-2104

**China - Chengdu**  
Tel: 86-28-8665-5511  
Fax: 86-28-8665-7889

**China - Chongqing**  
Tel: 86-23-8980-9588  
Fax: 86-23-8980-9500

**China - Hangzhou**  
Tel: 86-571-8792-8115  
Fax: 86-571-8792-8116

**China - Hong Kong SAR**  
Tel: 852-2943-5100  
Fax: 852-2401-3431

**China - Nanjing**  
Tel: 86-25-8473-2460  
Fax: 86-25-8473-2470

**China - Qingdao**  
Tel: 86-532-8502-7355  
Fax: 86-532-8502-7205

**China - Shanghai**  
Tel: 86-21-5407-5533  
Fax: 86-21-5407-5066

**China - Shenyang**  
Tel: 86-24-2334-2829  
Fax: 86-24-2334-2393

**China - Shenzhen**  
Tel: 86-755-8864-2200  
Fax: 86-755-8203-1760

**China - Wuhan**  
Tel: 86-27-5980-5300  
Fax: 86-27-5980-5118

**China - Xian**  
Tel: 86-29-8833-7252  
Fax: 86-29-8833-7256

**China - Xiamen**  
Tel: 86-592-2388138  
Fax: 86-592-2388130

**China - Zhuhai**  
Tel: 86-756-3210040  
Fax: 86-756-3210049

### ASIA/PACIFIC

**India - Bangalore**  
Tel: 91-80-3090-4444  
Fax: 91-80-3090-4123

**India - New Delhi**  
Tel: 91-11-4160-8631  
Fax: 91-11-4160-8632

**India - Pune**  
Tel: 91-20-3019-1500

**Japan - Osaka**  
Tel: 81-6-6152-7160  
Fax: 81-6-6152-9310

**Japan - Tokyo**  
Tel: 81-3-6880-3770  
Fax: 81-3-6880-3771

**Korea - Daegu**  
Tel: 82-53-744-4301  
Fax: 82-53-744-4302

**Korea - Seoul**  
Tel: 82-2-554-7200  
Fax: 82-2-558-5932 or  
82-2-558-5934

**Malaysia - Kuala Lumpur**  
Tel: 60-3-6201-9857  
Fax: 60-3-6201-9859

**Malaysia - Penang**  
Tel: 60-4-227-8870  
Fax: 60-4-227-4068

**Philippines - Manila**  
Tel: 63-2-634-9065  
Fax: 63-2-634-9069

**Singapore**  
Tel: 65-6334-8870  
Fax: 65-6334-8850

**Taiwan - Hsin Chu**  
Tel: 886-3-5778-366  
Fax: 886-3-5770-955

**Taiwan - Kaohsiung**  
Tel: 886-7-213-7830

**Taiwan - Taipei**  
Tel: 886-2-2508-8600  
Fax: 886-2-2508-0102

**Thailand - Bangkok**  
Tel: 66-2-694-1351  
Fax: 66-2-694-1350

### EUROPE

**Austria - Wels**  
Tel: 43-7242-2244-39  
Fax: 43-7242-2244-393

**Denmark - Copenhagen**  
Tel: 45-4450-2828  
Fax: 45-4485-2829

**France - Paris**  
Tel: 33-1-69-53-63-20  
Fax: 33-1-69-30-90-79

**Germany - Dusseldorf**  
Tel: 49-2129-3766400

**Germany - Munich**  
Tel: 49-89-627-144-0  
Fax: 49-89-627-144-44

**Germany - Pforzheim**  
Tel: 49-7231-424750

**Italy - Milan**  
Tel: 39-0331-742611  
Fax: 39-0331-466781

**Italy - Venice**  
Tel: 39-049-7625286

**Netherlands - Drunen**  
Tel: 31-416-690399  
Fax: 31-416-690340

**Poland - Warsaw**  
Tel: 48-22-3325737

**Spain - Madrid**  
Tel: 34-91-708-08-90  
Fax: 34-91-708-08-91

**Sweden - Stockholm**  
Tel: 46-8-5090-4654

**UK - Wokingham**  
Tel: 44-118-921-5800  
Fax: 44-118-921-5820

03/25/14